

NOTES:

- ALL DIMENSIONS IN MILLIMETRES UNLESS NOTED OTHERWISE.
- DN20 & DN25 SERVICES SHALL BE DN32 PN20 PE100 CHLORBLUE CC2 RATED WITH BLUE STRIPES CLEARLY MARKED TO AS4130. EQUIVALENT PRODUCTS MUST BE APPROVED BY PWC BEFORE USE.
- COPPER ALLOY SHALL BE DEZINCIFICATION RESISTANT (DR) TO AS 2345.
- NO WORK ON WATER CONNECTIONS MAY COMMENCE UNTIL THE CONTRACTOR HAS PWC APPROVED COPIES OF THE SITE SERVICES PLAN AND "WATER AND SEWER CONNECTION APPLICATION FORM - REMOTE OPERATIONS" AND PAID ALL FEES.
- ONLY PWC (OR ITS AUTHORISED CONTRACTORS) ARE PERMITTED TO TAP EXISTING, IN-SERVICE (LIVE) MAINS OR MAINS THAT HAVE BEEN HYDROSTATICALLY TESTED. WITHIN LICENSED AREAS AND UPON PAYMENT OF THE NECESSARY FEES, PWC WILL PERFORM TAPPING OF LIVE MAINS, HOWEVER, EXCAVATION, ALL MATERIALS AND INSTALLATION SHALL BE SUPPLIED BY THE CONTRACTOR.
- A BACKFLOW CERTIFIED PLUMBER IS REQUIRED TO DETERMINE THE RISK OF CONTAMINATION OF THE POTABLE WATER SUPPLY DUE TO CROSS CONNECTIONS AND WHERE MEDIUM HAZARD AND HIGH HAZARD RISKS ARE IDENTIFIED (REFER AS/NZS 3500), PROVIDE APPROPRIATE BACKFLOW DEVICES.
- FOR DETAILS OF APPROVED PRODUCTS USED ON THIS DRAWING, REFER TO THE WATER AND SEWERAGE INFRASTRUCTURE PRODUCTS MANUAL.
- ON COMPLETION OF WATER SERVICE, PROVIDE BRASS PLUG FITTED TO OUTLET.
- WHERE SEPARATE BACKFLOW DEVICES ARE FITTED BY THE LAND OWNER IN ACCORDANCE WITH NOTE 6 ABOVE, WATER METERS DO NOT REQUIRE INTEGRAL DUAL CHECK VALVES.
- PE PIPES AND FITTINGS SHALL NOT BE USED IN AREAS CONTAMINATED OR EXPECTED TO BE CONTAMINATED BY PETROLEUM BASED PRODUCTS, SUCH AS SOLVENT FOR TERMITE/PEST CONTROL TREATMENT OR PAINT.
- THE EDGE OF CONCRETE METER PAD IS TO ALIGN WITH PROPERTY ROAD AND SIDE BOUNDARY.
- PE SERVICE PIPE IS TO BE INSTALLED AS A CONTINUOUS LENGTH OF PIPE WITH NO JOINS.
- MIN COVER TO SERVICE : 450mm WITHIN PROPERTY BOUNDARY, 750mm ELSEWHERE.
- USE SILVER BRAZING (MIN 2% SILVER) TO AS1167.1 FOR ALL CAPILLARY JOINTING OF COPPER PIPES AND FITTINGS.
- MINIMUM 100mm EMBEDMENT AND 150mm OVERLAY, TYPE 1 OR TYPE 4 MATERIAL IN GEOFABRIC FOR FULL LENGTH OF SERVICE CONNECTION.
- FOR NEW RETICULATION MAINS, INSTALL PRE-TAPPED CONNECTOR (REFER TO W1-1-23A) IN LIEU OF TAPPING BAND.
- SWEPT BEND TO BE FORMED USING PIPE BENDER OR BENDING SPRING WITH A BEND RADIUS GREATER THAN FIVE TIMES THE OUTSIDE DIAMETER OF THE COPPER PIPE.
- IDENTIFY EACH PROPERTY OFFTAKE WITH A 50X 50X 2 ALUMINIUM PLATE IDENTIFICATION TAG WITH UNIT NUMBER STAMPED IN 10MM HIGH LETTERS. WIRE TAG TO METER TAP WITH 3MM GALVANISED WIRE.

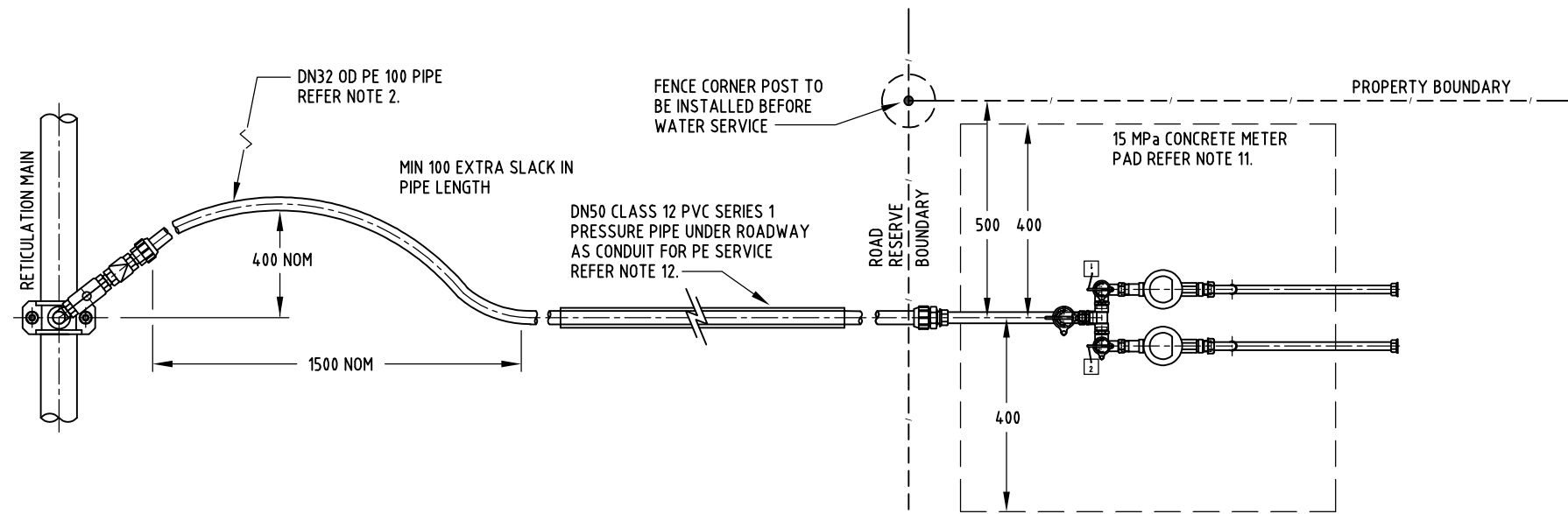
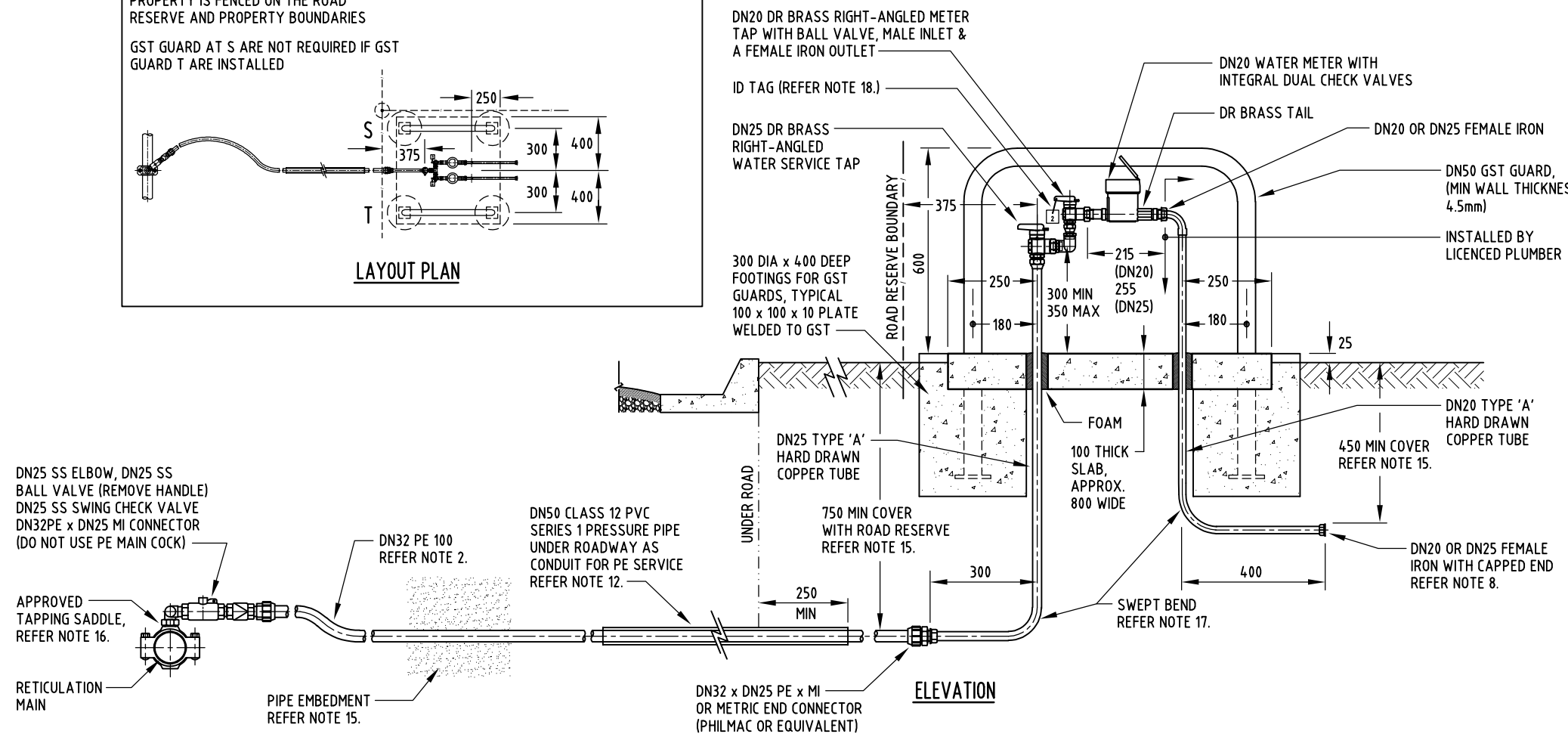
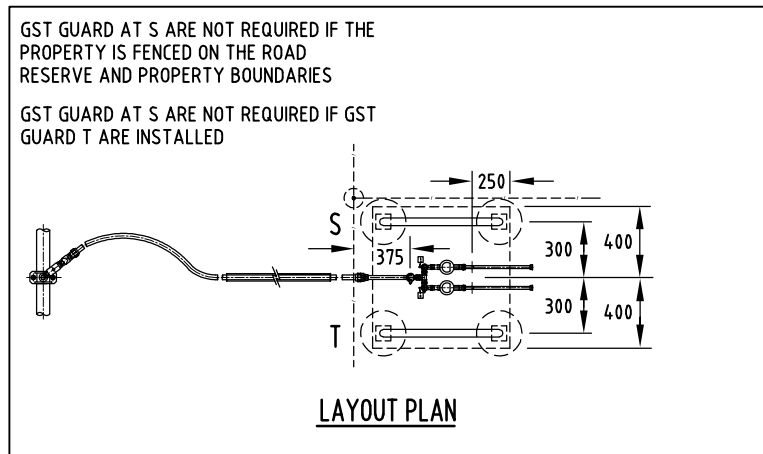

TABLE 1 - ACCEPTABLE EQUIVALENT SIZES

SPECIFIED NOM SIZE DN	COPPER DN	PE DN
20	20	32



NO	DESCRIPTION	DRN	DATE	CKD	APPD
2	NOTE 2 & GENERAL AMENDMENTS 2022	PW	SEPT'22	JC	DC
1	GENERAL AMENDMENTS	TJK	15/3/17	N.M.	PWC
0	NEW-ISSUED FOR PWC	K.I.	24/1/12	R.N.	PWC



DES	R.HUTCHINS	WATER STANDARD DRAWING	
DRN	K.IBBOTT	SERVICE - DN20 ABOVE GROUND METER FOR DUPLEX	
CHK	R.HUTCHINS	Polyethylene / Copper - Non Corrosive Conditions	
APPD	PWC	Remote Operations Services - South of Tennant Creek	
SCALE	N.T.S.	A3	DRAWING NUMBER ROW1-1-326
ISSUED	JAN'12		
ALL DIM. IN mm			2
DRAFTING STANDARD TO A.S.1100		CAD PRODUCT - DO NOT AMEND MANUALLY	