

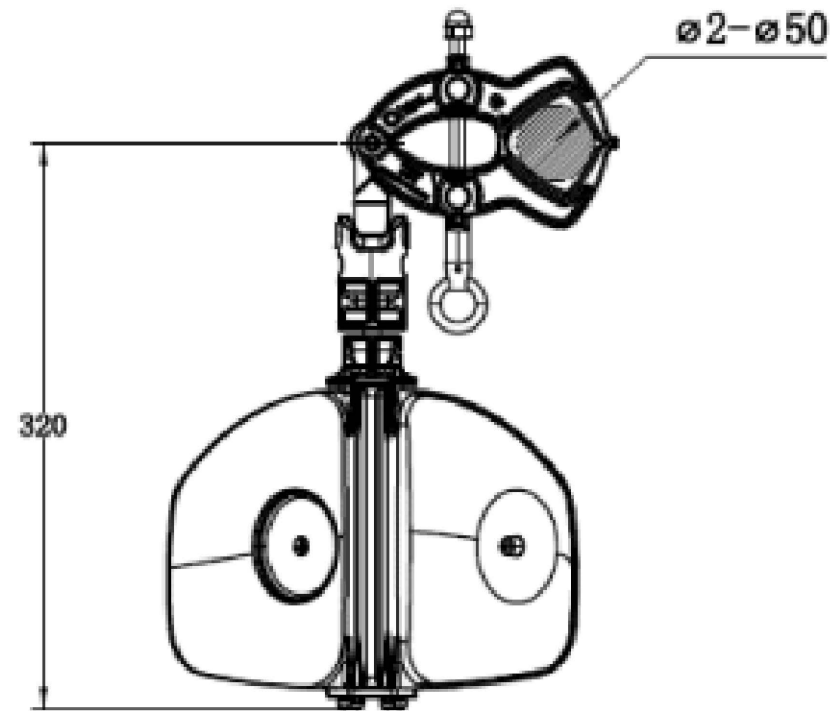

ISOMETRIC VIEW
N.T.S

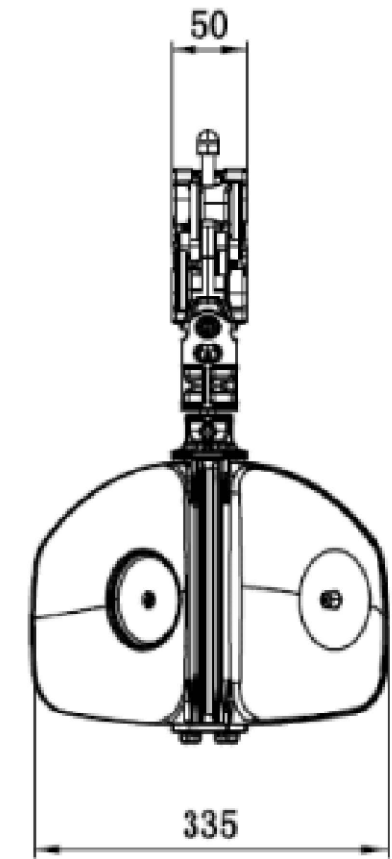

FRONT VIEW
N.T.S



SIDE VIEW
N.T.S

MATERIAL TABLE

ROTAMARKA™ SCREW CLAMP EYE RING RED WHITE	
CLAMP, BODY & FINS	NYLON 6
SOFT JAW	TPE
BEARINGS	STAINLESS STEEL
PINS & BUSHES	BRASS
THREADED SHAFT	STAINLESS STEEL
LOCK NUTS	BRASS + STAINLESS STEEL
REFLECTORS	ACRYLIC

RATINGS TABLE

SPACING BETWEEN THE DEVICE	1-3M or 1-2 MARKERS SPACED BETWEEN 2 POLES OR TOWERS
RECOMMENDED TIGHTENING TORQUE	4NM
COEFFICIENT OF DRAG	1.11
LINE LOAD (PER UNIT) AT WIND SPEED OF 18KPH AT WIND SPEED OF 36KPH AT WIND SPEED OF 108 KPH	0.8N (82g) 3.0N (306g) 27N (2753g)
AS 3891.2 - 2018	COMPLIANT

ITEM NUMBER: 505063

						DES	B.CHEUNG	POWER STANDARD DRAWING			
						DRN	J.REYES	LINE HARDWARE			
						CKD	B.BAYRAM	ROTATIONAL AERIAL MARKER			
						APPD	B.VANDERSTELT				
						SCALE	NTS				
						ISSUED	NOV'24	A3	DRAWING NUMBER	S01-01-04-59	
						ALL DIM. IN mm					
						DRAFTING STANDARD TO A.S.1100					
0	ISSUED FOR CONSTRUCTION	J.R.	NOV'24	B.V.	B.C.						
NO	DESCRIPTION	DRN	DATE	CKD	APPD						
AMENDMENTS											

