

PLAN VIEW

N.T.S.

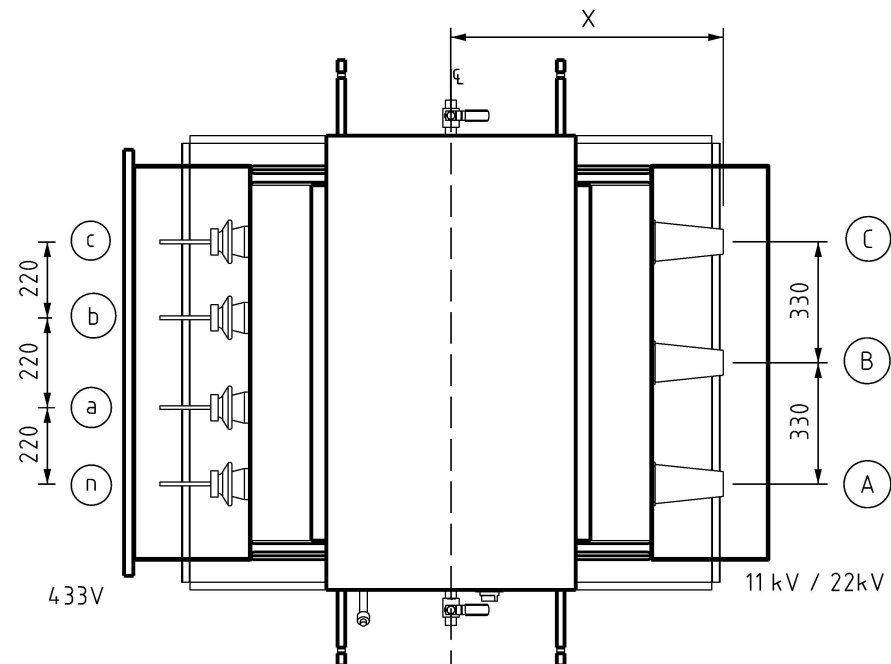

SECTION VIEW

N.T.S.

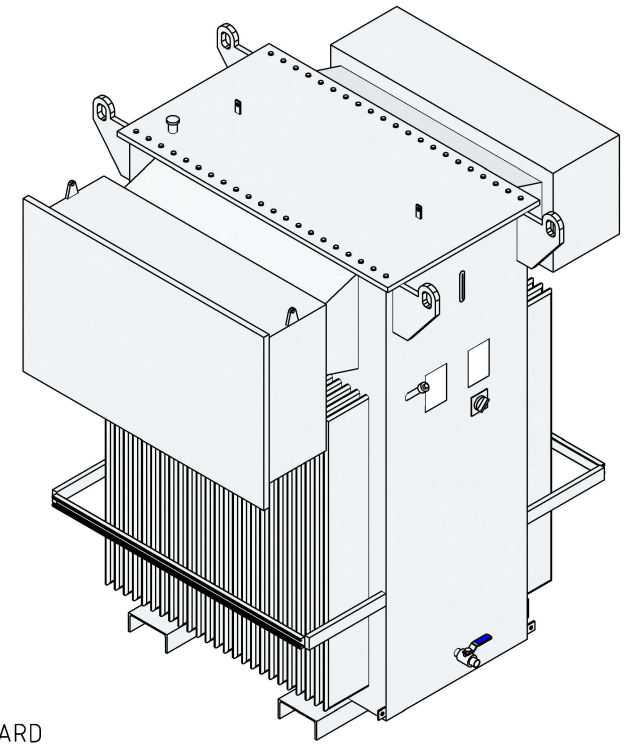

ISOMETRIC VIEW

N.T.S.

NOTES:

1. TRANSFORMER MUST COMPLY WITH PWC STANDARD TECHNICAL SPECIFICATION STSP 02-007.
2. HV CABLE BOX AND LV TERMINAL COVER TO BE REVERSIBLE.
3. VECTOR GROUPING TO BE Dyn1.
4. 7 HV WINDING TAPS SHALL BE PROVIDED +10% to -5% IN STEPS OF 2.5%.
5. DIMENSION 'X' REFERS TO THE DISTANCE FROM EXTREMITY OF HV TERMINAL TO CENTERLINE

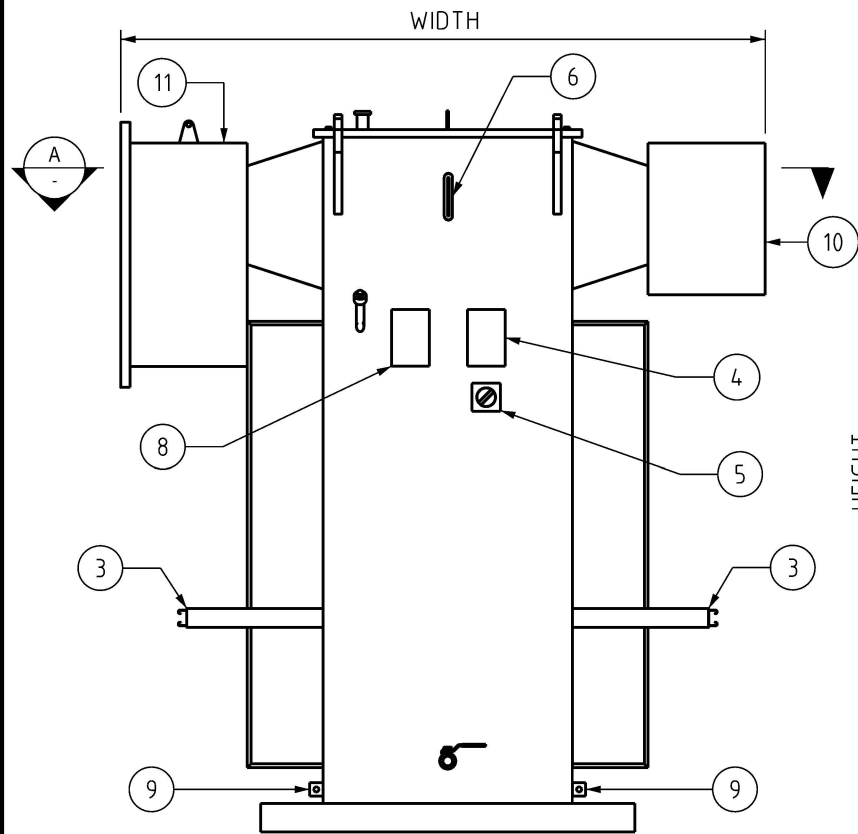

FRONT ELEVATION

N.T.S.

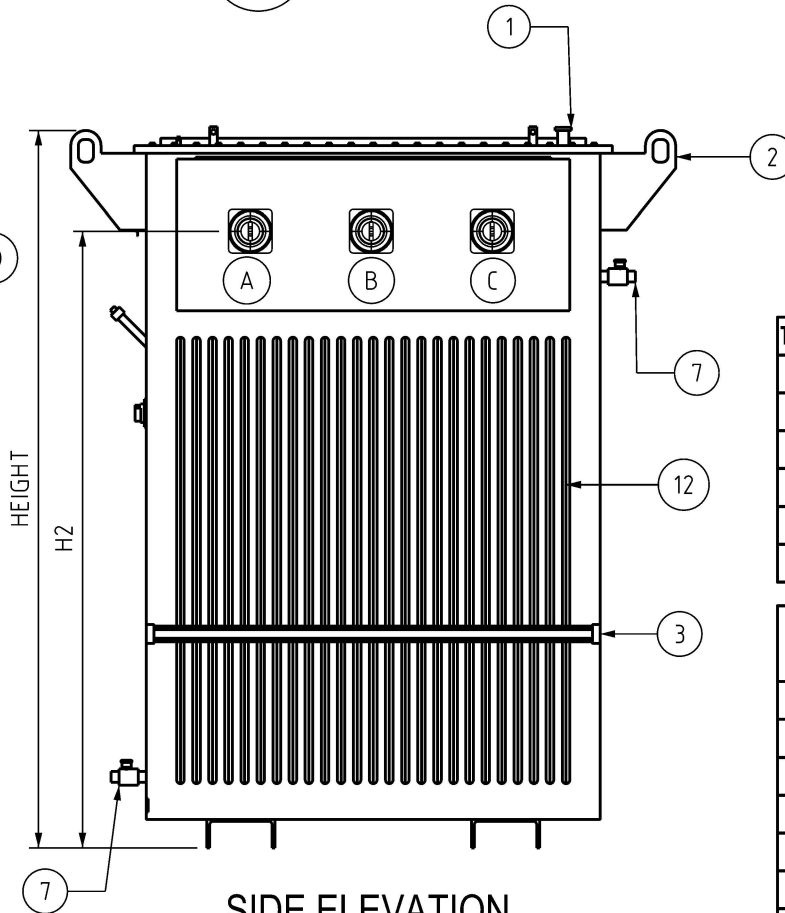

SIDE ELEVATION

N.T.S.

TAG No	DESCRIPTION	TAG No	DESCRIPTION
1	FILLER SPOUT c/w GASKETTED FLANGE PLUG	7	DRAIN VALVE 25mm c/w GASKETTED FLANGE PLUG
2	LIFTING LUG	8	NUMBER PLATE BRACKET
3	CABLE SUPPORT UNISTRUT P3300-GALVANISED	9	EARTH STUD
4	NAME PLATE	10	LV BUSHING COVER
5	TAP SELECTOR	11	HV CABLE BOX c/w BRASS GLAND PLATE
6	FLUSH TYPE OIL GUAGE	12	COOLING FIN

ITEM	SIZE	VOLTAGE		ITEM NUMBER	HEIGHT	WIDTH	LENGTH	X	H2	MASS
		PRIM	SEC							
1	500kVA	11kV	400V	503678	1647	1594	1314	623	1329	2405
2	750kVA	11kV	400V	503680	1677	1704	1504	678	1359	3313
3	1000kVA	11kV	400V	503681	1947	1709	1514	680	1629	4055
4	1500kVA	11kV	400V	503679	2247	1749	1794	700	1929	5176
5	500kVA	22kV	400V	503675	1535	1572	1326	610	1236	2500
6	750kVA	22kV	400V	503676	1671	1708	1549	678	1325	3465
7	1000kVA	22kV	400V	503677	1947	1733	1590	690	1629	3955
8	1500kVA	22kV	400V	503541	2247	1809	1794	730	1929	5714

NO	DESCRIPTION	DRN	DATE	CKD	APPD
3	NOTE 5 AMENDED.	P.BH.	JUL'23	B.C.	B.V.
2	UPDATED SECONDARY VOLTAGES TO 400V, UPDATED STANDARD SPECIFICATION TO STSP 02-007, ADDED ADDITIONAL DIMENSIONS & UPDATED NOTE 4 & 5	A.N.	SEP'20	C.C.C.	B.C.
1	INCLUDE ADDITIONAL DIMENSIONS	C.C.	MAR'19	B.C.	B.V.
0	ISSUED FOR CONSTRUCTION	A.B.	JUN'17	A.T.	B.C.
AMENDMENTS					



DES		POWER STANDARD DRAWING	
DES	A.BRUMMITT	TRANSFORMERS, SMALL FOOTPRINT, 11kV & 22kV - PLATFORM - INDOOR 500, 750, 1000 AND 1500kVA	
DRN	A.BRUMMITT		
CKD	A.TAYLOR		
APPD	B.CHEUNG		
SCALE	N.T.S.		
ISSUED	JUNE 2017	A3	DRAWING NUMBER S02-01-06-10
ALL DIM. IN mm			
DRAFTING STANDARD TO A.S.1100		CAD PRODUCT - DO NOT AMEND MANUALLY	

