

**SIDE VIEW**  
SCALE 1:50

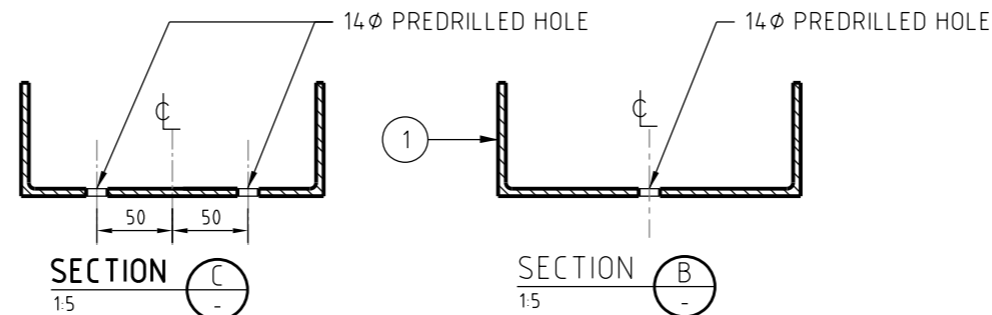
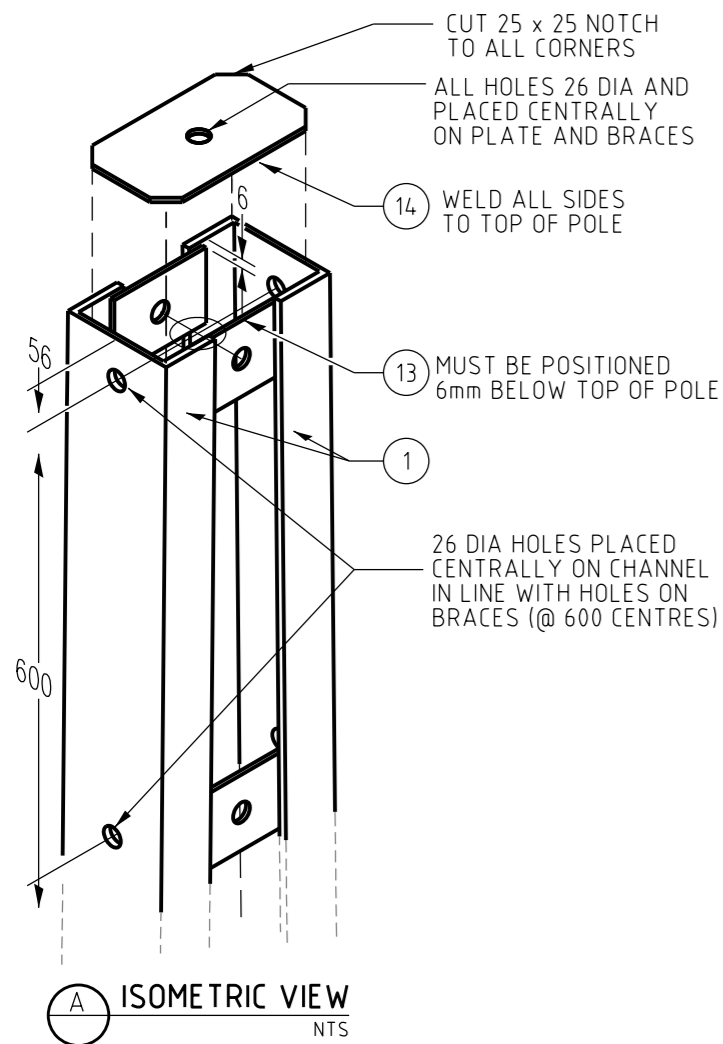

**LINE POLE 18.5D - ITEM NUMBER : 299396**

HD GALVANISED - ITEM NUMBER : 501247

**NOTES**

- TOP PLATE AND BASE PLATE DO NOT FORM PART OF THE OVERALL DIMENSION
- BRACES AND GROUND PLATE TO BE WELDED ON INSIDE OF POLE AND TO HAVE 17mm MIN OVERLAP. ANTI-CLIMBING PLATE TO BE WELDED ON OUTSIDE OF POLE
- ALL WELDS TO BE 6mm FILLET CONTINUOUS WELD EXCEPT ANTI-CLIMBING PLATE WHICH IS TO HAVE 6mm FILLET 150mm LONG AT BOTH ENDS AND CENTRE
- ALL ROUGH OR BURRED EDGES ARE TO BE DRESSED CLEAN
- STEEL TO BE GRADE 300 PLUS
- PFC DIMENSIONS ARE TO AS 3679
- WELDING TO COMPLY WITH AS 1554
- TOLERANCES TO DIMENSIONS OVER 5m IS +/- 5mm
- EACH POLE IS TO BE ENGRAVED WITH THE SIZE, TARE WEIGHT, FABRICATORS NAME, AND MONTH AND YEAR OF FABRICATION
- ENGRAVING SHALL BE IN LETTERS NO LESS THAN 10mm HIGH AND 0.05mm DEEP AND POSITIONED ON THE FIRST GUSSET PLATE ABOVE GROUND LEVEL
- POLES TO COMPLY WITH STSP 01-002
- 14mm PREDRILLED HOLES FOR EARTH BOND AND NEUTRAL BOND TERMINATION

ITEM	QTY	MATERIAL DESCRIPTION
1	2	250 x 90 PFC, 18500 LONG
2	1	950 x 238 x 10 FMS, BASE PLATE
3	4	850 x 200 x 10 FMS, FOOTING BRACES
4	6	770 x 200 x 10 FMS, FOOTING BRACES
5	2	750 x 500 x 10 FMS, GROUND PLATE
6	6	700 x 200 x 10 FMS, BRACES UNDER A/CL PLATE
7	2	650 x 1400 x 6 FMS, ANTI-CLIMBING PLATE
8	8	540 x 200 x 10 FMS, MID BRACES
9	10	430 x 200 x 10 FMS, MID BRACES
10	2	330 x 200 x 10 FMS, MID BRACES
11	8	330 x 200 x 10 FMS, BRACES, 26 DIA HOLE
12	6	220 x 200 x 10 FMS, BRACES, 26 DIA HOLE
13	2	220 x 100 x 10 FMS, BRACES, 26 DIA HOLE
14	2	268 x 238 x 10 FMS, TOP PLATE 26 DIA HOLE, NOTCHED 25x25 EACH CORNER

NO	DESCRIPTION	DRN	DATE	CKD	APPD
6	AMENDED QTY OF ITEMS 3,4,6,9,11, AND 12 TO DISPLAY CORRECT VALUES	J.R.	DEC'23	B.C.	B.V.
5	AMENDED ITEM 14. IMPROVED IMAGERY. AMENDED NOTE 5. ADDED NOTES 11 & 12	P.G.	MAR'23	B.V.	B.C.
4	ADDED ADDITIONAL EARTH CONNECTION AT POLE BASE. REMOVED ITEM 15.	K.T.	DEC'18	C.C.	C.C.
	TITLEBLOCK & DRAWING NUMBER FORMATTED, HD GALVANISED ITEMS ADDED				
3	13mm HOLES FOR PADLOCK ADDED	K.I.	OCT'05	C.C.	C.C.
2	M12 x 40 LONG GALV BOLTS ITEM 12 ADDED, ITEM 6 RAISED	A.S.	MAY'03	R.C.	M.B.
1	MSTOCK CODE ADDED	A.S.	MAY'03	R.C.	M.B.
0	ISSUED FOR CONSTRUCTION	A.S.	MAR'01	M.B.	F.R.R.



DES		POWER STANDARD DRAWING	
M. BOCK		POLES	
R. INNES		LINE 18.5D	
R. CLEOPAS		BOLTED CONNECTIONS TYPE	
M. BOCK			
AS NOTED			
FEB '01		A3	DRAWING NUMBER S01-01-01-15
IN mm			
TO A.S.1100			CAD PRODUCT - DO NOT AMEND MANUALLY

