

**ITEM 3 - EARTH MAT (AIR BREAK SWITCH)**

(ITEM NUMBER 11882)

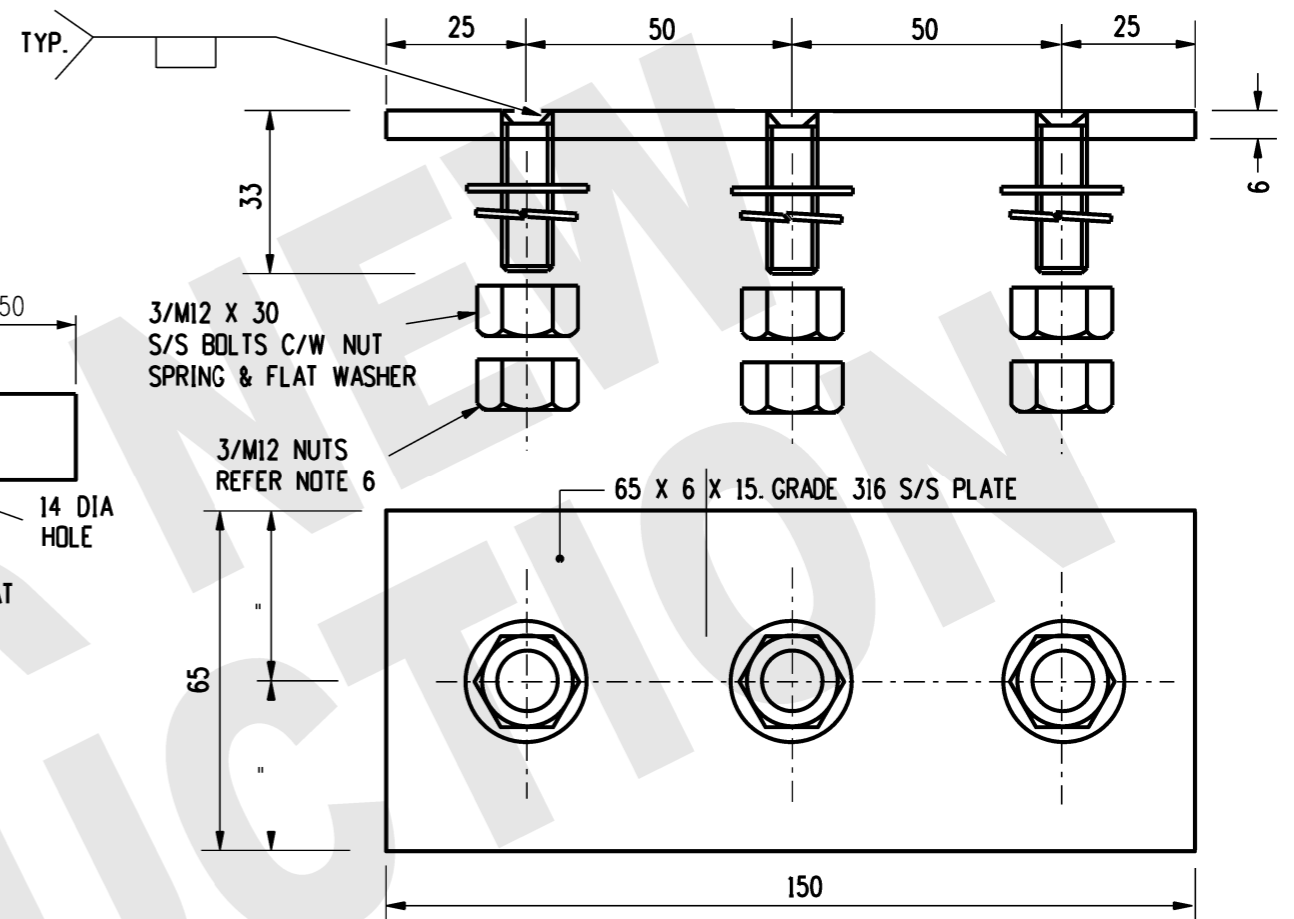
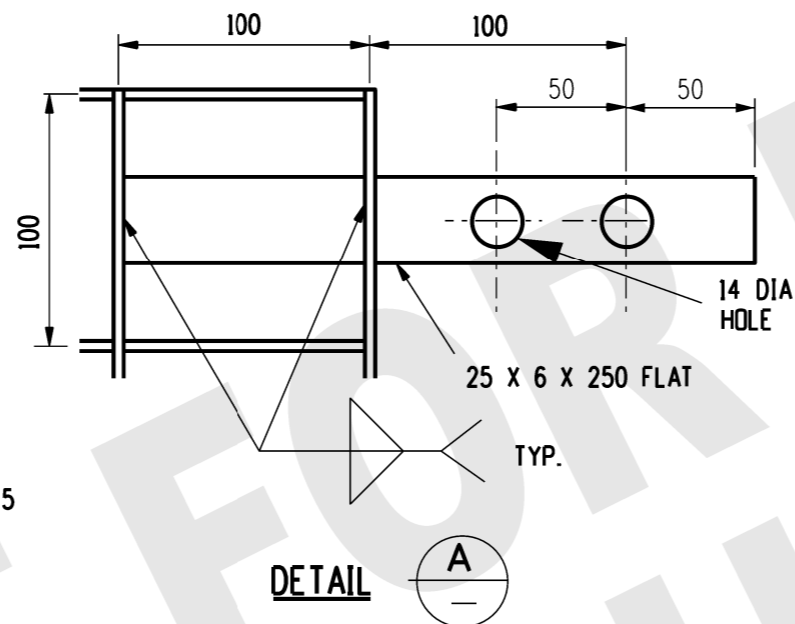

**ITEM 1 - EARTH TEST LINK**

(ITEM NUMBER 9142) NOT FOR USE ON BOLTED POLES

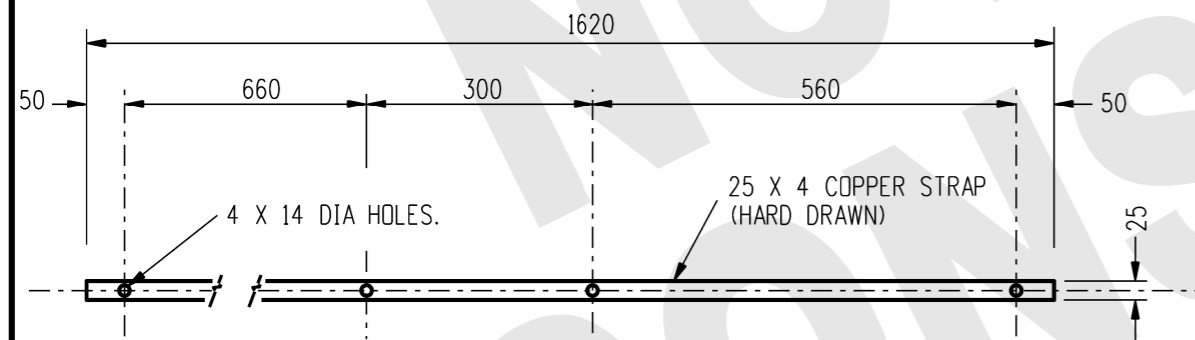

**ITEM 2 - EARTHING BUSBAR - HV METAL OXIDE DIVERTER**

(ITEM NUMBER - 251413)

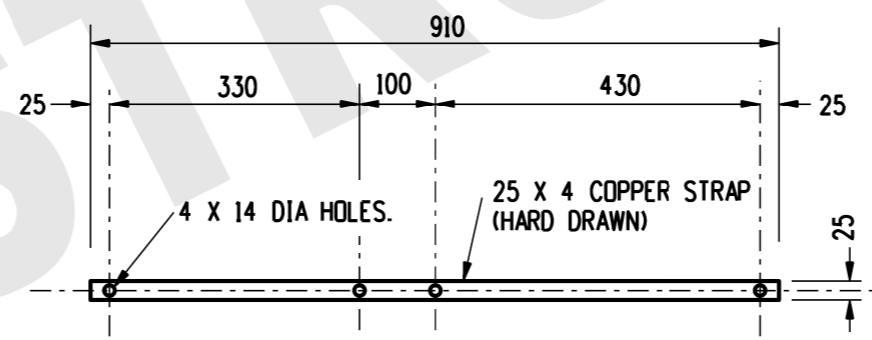

**ITEM 4 - EARTHING BUSBAR - HV METAL OXIDE DIVERTER**

(ITEM NUMBER - 251405. FOR STANDOFF CROSSARMS)

**NOTES**

1. ALL WORKMANSHIP AND MATERIALS SHALL BE IN ACCORDANCE WITH AS3678 UNLESS OTHERWISE NOTIFIED.
2. ALL WELDING AND WELD PREPARATION SHALL BE IN ACCORDANCE WITH AS1554. FILLET WELDS TO BE 6mm UNLESS OTHERWISE NOTIFIED.
3. ALL ROUGH OR BURRED EDGES ARE TO BE DRESSED CLEAN.
4. BOLTS TO BE METRIC, PROPERTY CLASS 4.6 AND SHALL BE IN ACCORDANCE WITH AS1111.
5. ITEM 3 - TO BE HOT DIPPED GALVANISED, WHEREBY COMPONENTS ARE TO BE EVEN, FREE OF LUMPS, BUILD-UP AND TRUE TO SHAPE AFTER GALVANISING. COMPONENTS WILL BE TESTED IN ACCORDANCE WITH AS4680.
6. ADDITIONAL OUTER NUTS (3) ARE REQUIRED FOR PROTECTION OF STUDS DURING SITE WELDING TO LINE POLE, AND ARE NOT NEEDED FOR TERMINATION OF EARTHING CABLE LUGS.

14	UPDATED TO NOT FOR NEW CONSTRUCTION	J.R.	JUL'24	B.B.	B.V.
13	TITLEBLOCK & DRAWING NUMBER FORMATTED	K.T.	DEC'18	C.C.	C.C.
12	ITEM ONE NOTE ADDED	K.I.	SEP'05	C.C.	C.C.
11	AUSTRALIAN STANDARDS ALTERED, ITEM 4 DESCRIPTION AMENDED.	J.A.L.	JAN'97	S.M.	F.R.R.
10	GRADE OF S/S ADDED.	G.R.	FEB'94	pmc	C.H.Y.
9	S/C 3301 DELETED. ITEM 1 REVISED. ITEM 2 REVISED & NOW S/C 250829. ITEM 4 ADDED.	gmck	OCT'92	N.S.	B.T.K.
8	REDRAWN AND REVISED	g.l.	MAY'89	-	B.T.K.
NO	DESCRIPTION	DRN	DATE	CKD	APPD
AMENDMENTS					

**PowerWater**

NORTHERN TERRITORY

DES	G.S.	POWER STANDARD DRAWING		
DRN	G.L.	<b>EARTHING SURGE DIVERTER BUSBAR</b>		
CKD	G.S/GMCK			
APPD	B.T.KENT			
SCALE	N.T.S.			
ISSUED	MAY'89	<b>A3</b>	<b>DRAWING NUMBER</b>	<b>S01-01-05-02</b>
ALL DIM.	IN mm			
DRAFTING STANDARD TO A.S.1100		CAD PRODUCT - DO NOT AMEND MANUALLY		

