

3RD ANGLE — DO NOT SCALE — REPORT ANY ERRORS, OMISSIONS TO DRAFTING OFFICE

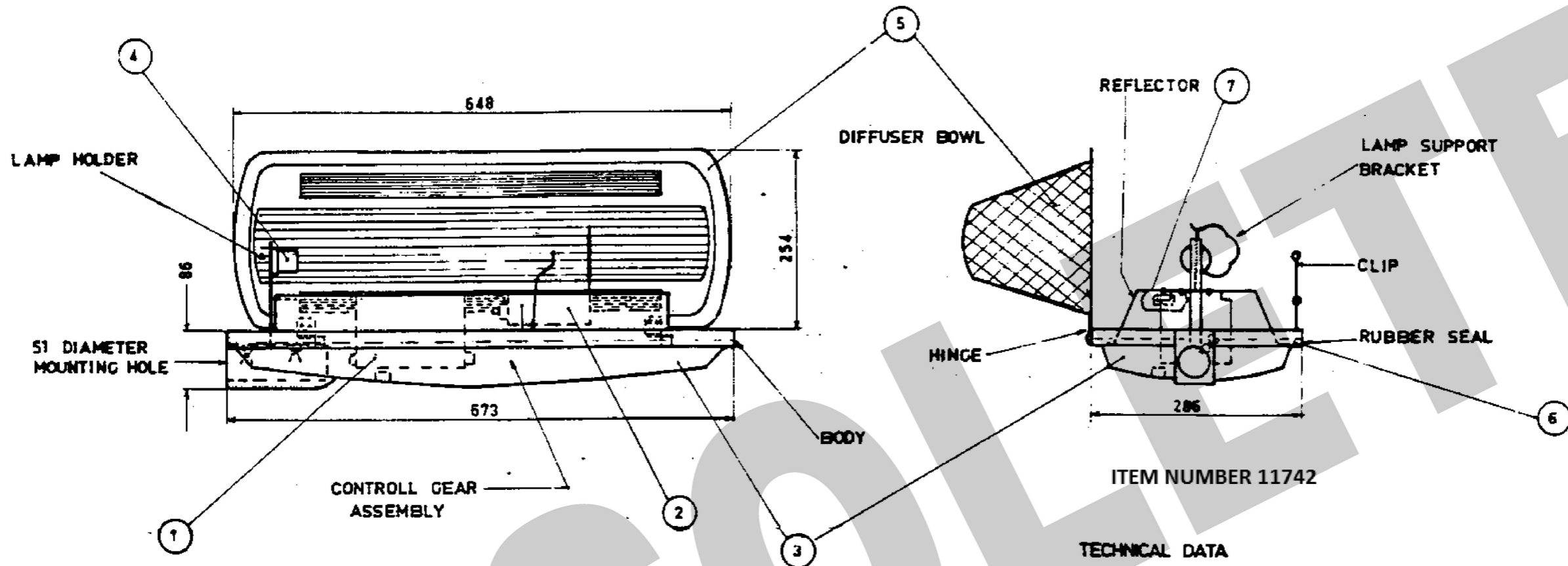

ITEM NUMBER 11742

**TECHNICAL DATA**  
 FOR OUTDOOR USE UNDER EXTREME TROPICAL CONDITIONS.  
 AS 1158  
 SPECIAL CRITERIA FOR N.T. PUBLIC LIGHTING LANTERNS.

- 1..DELETION OF BUILT IN FUSE WITHIN LANTERN.
- 2..PROVISION OF REMOVABLE CONTROL GEAR TRAY.
- 3..PROVISION OF QUICK DISCONNECT PLUG BETWEEN PORCELAIN BLOCK AND REMOVABLE TRAY.(SIMILAR TO UTILUX M/N 1545-2)
- 4..EARTH ATTACHMENT TO BODY OF LANTERN.
- 5..LANTERN TO COMPLY WITH AS3771 FOR CATEGORY 'B' ROAD LUMINAIRES.

**NOTE**  
 1 CONTROL GEAR ASSEMBLY SHALL INCLUDE —  
 LEAKAGE TRANSFORMER SIMILAR TO FERGUSON TYPE SA 140SB  
 PAPER CAPACITOR 20MFD ± 10% SIMILAR TO DUCON TYPE APS 2200

N <sup>o</sup>	QTY	DESCRIPTION
7	1	REFLECTOR - IRON SHEET
6	1	SEAL - RUBBER
5	1	BOWL - PERSPEX
4	1	LAMP HOLDER - PORCELAIN
3	1	BODY - CAST ALLOY
2	1	CAPACITOR 20 MFD FOR 90W
1	1	LANTERN SV 90W INTRGRAL
MATERIALS SCHEDULE		

NO	DESCRIPTION	DRN	DATE	CKD	APPD
6	OBSOLETE	A.N.	AUG'21	C.C.C.	B.V.
5	TITLEBLOCK & DRAWING NUMBER FORMATTED	K.T.	MAY'19	C.C.	C.C.
4	NOTES AMENDED	R.T.F	FEB'91	-	-
3	NOTE 6 ADDED	-	6/89	-	-
2	TITLE & DRAWING NUMBER CHANGED	-	12/87	-	-
1	STOCK CODE AMENDED	W.T.	01/87	-	-
AMENDMENTS					

**PowerWater**  
 NORTHERN TERRITORY

DES	G.McS	POWER STANDARD DRAWING	
DRN	RPP	LANTERN & LAMPS MINOR ROADS SODIUM VAPOUR 90W (SOX)	
CKD	G.McS		
APPD	-	A3	DRAWING NUMBER S03-01-04-02
SCALE	-		
ISSUED	20/02/86	DRAWING NUMBER S03-01-04-02	
ALL DIM.	IN mm		
DRAFTING STANDARD TO A.S.1100		CAD PRODUCT - DO NOT AMEND MANUALLY	

6  
 AMDT