

ITEM 1: 630A SWITCH-FUSE DISCONNECTOR

ITEM NUMBER: 11866

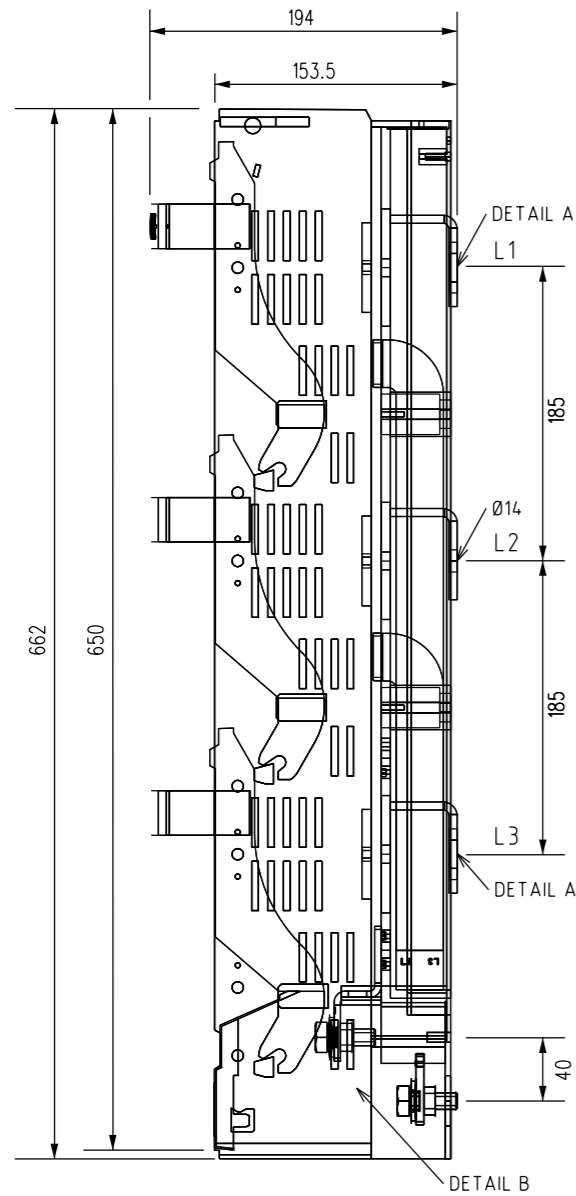

DETAIL B:

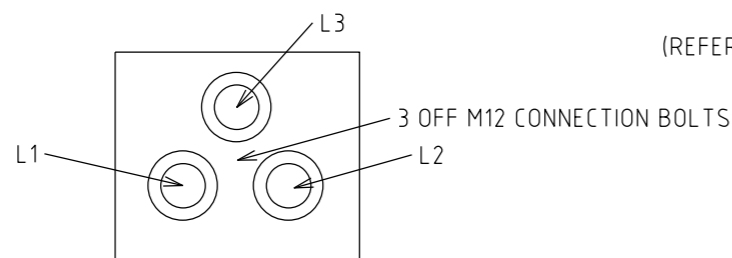

ITEM 2: 1000A SWITCH-FUSE DISCONNECTOR

ITEM NUMBER: 292276

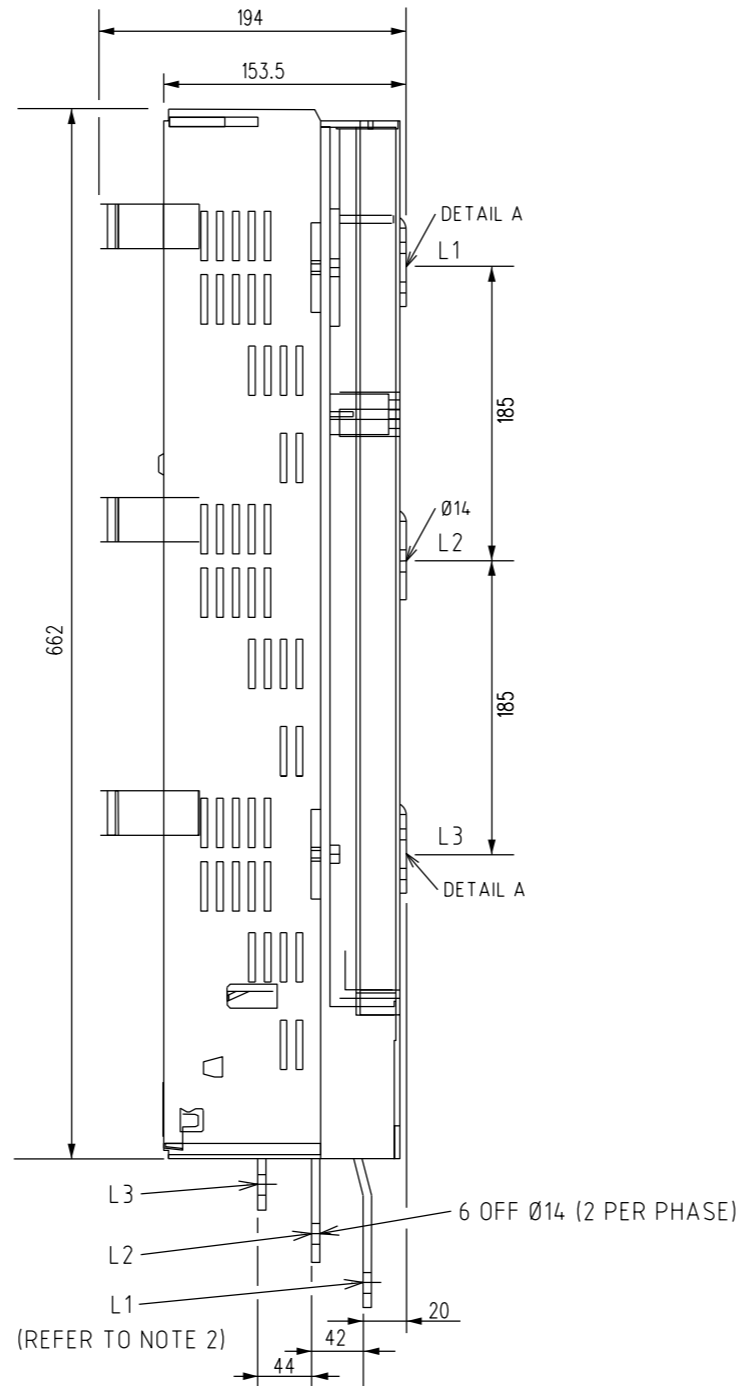

(REFER TO NOTE 2)

ATTRIBUTE	ITEM NUMBER	
	11866	292276
RATED OPERATIONAL CURRENT I_e	630 A	1000 A
MINIMUM RATED OPERATION VOLTAGE U_e	500 V	
MINIMUM RATED INSULATION VOLTAGE U_i	750 V	
RATED FREQUENCY	50 Hz	
RATED CONDITIONAL SHORT-CIRCUIT CURRENT I_{cc}	120 kA	
RATED SHORT-TIME WITHSTAND CURRENT	10 kA	
RATED MAKING CAPACITY	1500 A	2400 A
UTILIZATION CATEGORY	AC-22B - AS/IEC 60947.3	
LINKS - DIN 43-620 SIZE	3	
FUSE LINKS - RATED CURRENT	630 A	1000 A
SOLID LINKS - RATED CURRENT	800 A	1250 A
CABLE CONNECTION - METHOD	M12 BOLTS	
CABLE CONNECTION - NOMINAL TORQUE	40 Nm	
TYPE OF ACTUATION	DEPENDENT MANUAL OPERATION	
TYPE OF SWITCHING	SINGLE POLE	
MOUNTING POSITION	VERTICAL	
IP RATING - OPERATIONAL STATE (FRONT)	IP2X	
IP RATING - COVER OPEN	IP1X	
MECHANICAL ENDURANCE	≥500 OPERATIONS	
ELECTRICAL ENDURANCE	≥100 OPERATIONS	
NOMINAL WIDTH	99 mm	
NOMINAL DEPTH - CLOSED	194 mm	
BUSBAR HOLE CENTRES	185 mm	

NOTES:

- FOR FUSE AND SOLID LINK SIZES REFER TO DWG. S02-01-04-10
- 1000 A SWITCH-FUSE DISCONNECTOR (ITEM NUMBER 292276) TO BE SUPPLIED FITTED WITH 3 OFF 1250 A SOLID LINKS.
- ITEMS TO BE SUPPLIED WITH SUITABLE M12 BOLTS AND WASHERS (3 OFF EACH) FOR BUSBAR CONNECTION.

DETAIL A:

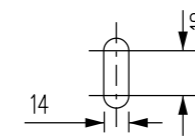

NO	DESCRIPTION	DRN	DATE	CKD	APPD
5	ITEMS & TABLE UPDATED. CONSOLIDATED ITEMS. UPDATED NOTE 1. ADDED NOTES 2 & 3.	A.N.	AUG'21	C.C.C.	B.V.
4	TITLEBLOCK & DRAWING NUMBER FORMATTED	K.T.	FEB'19	C.C.	C.C.
3	TITLE AND TABLE AMENDED	A.S.	AUG'06	S.D.	B.C.
2	ADD NEW WEBER UPDATE NOTES & DETAILS	K.I.	FEB'05	R.C.	C.C.
1	WEBER PART No.s CHANGED	G.Mc	AUG'93	A.G.	
AMENDMENTS					



DES	R.C.	POWER STANDARD DRAWING		
DRN	K.I.	FUSES AND SWITCHGEAR FUSE BASE STRIPLE FUSE 630-1000A		
CKD	C.C.			
APPD	...			
SCALE	N.T.S.			
ISSUED	DEC '04	A3	DRAWING NUMBER	S02-01-04-08
ALL DIM.	IN mm			
DRAFTING STANDARD TO A.S.1100		CAD PRODUCT - DO NOT AMEND MANUALLY		5 AMDT