

TOP VIEW  
SCALE 1:1

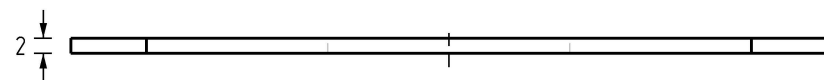

FRONT VIEW  
SCALE 1:1

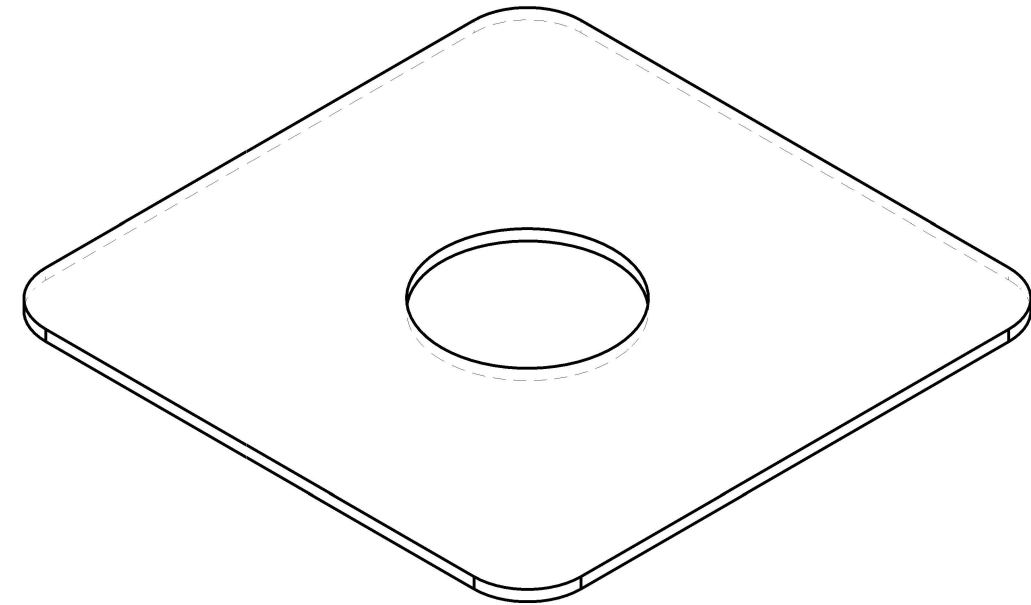

ISOMETRIC VIEW  
SCALE 1:1 ITEM NUMBER : 504966

**NOTES:**

1. TO BE MANUFACTURED FROM MILD STEEL GALVANIZED PLATE. EXPOSED EDGES TO BE COLD GALVANIZED.
2. FABRICATION AND GALVANISATION TO COMPLY WITH PWC STANDARD TECHNICAL SPECIFICATION STSP 01-002.
3. ALL SHARP EDGES & BURRS TO BE REMOVED.
4. TO BE SECURED IN POSITION OVER COVER SECURING SPIGOT BETWEEN PADLOCK AND TOP OF PILLAR COVER. REFER TO DWG S02-01-03-06.

NO	DESCRIPTION	DRN	DATE	CKD	APPD
0	ISSUED FOR CONSTRUCTION.	P.BH.	OCT'22	B.V.	B.C.
AMENDMENTS					



DES	B. VANDERSTELT	POWER STANDARD DRAWING		
DRN	P. BHATTARAI	DISTRIBUTION PILLARS FUSED TYPE PADLOCK SECURING PLATE		
CKD	B. VANDERSTELT			
APPD	B. CHEUNG	A3	DRAWING NUMBER	S02-01-03-17
SCALE	AS SHOWN			
ISSUED	OCT'2022	CAD PRODUCT - DO NOT AMEND MANUALLY		
ALL DIM. IN	mm			
DRAFTING STANDARD TO A.S.1100		AMDT		