

1 Set 240mm², 4 core Aluminium

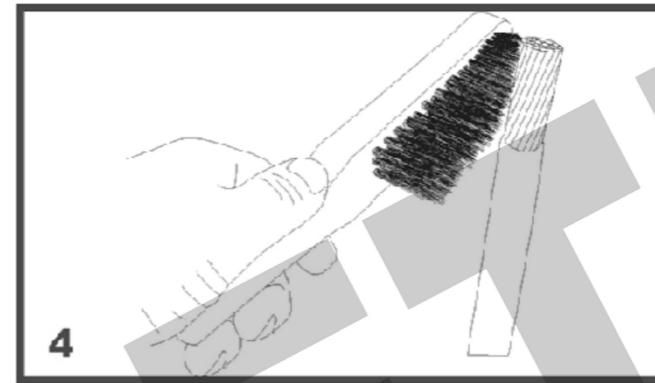

4 Scratch brush each conductor

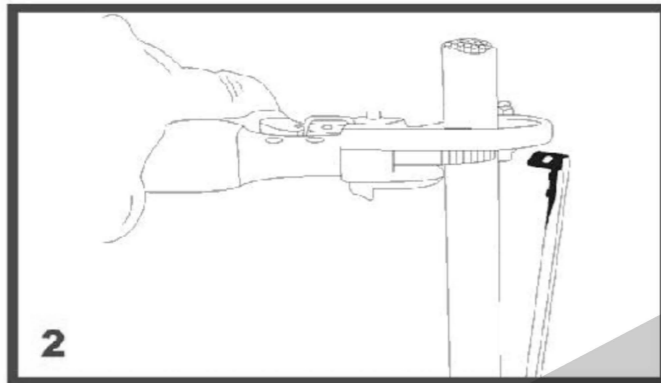

2 Cut conductor 390mm from the top of the pillar base

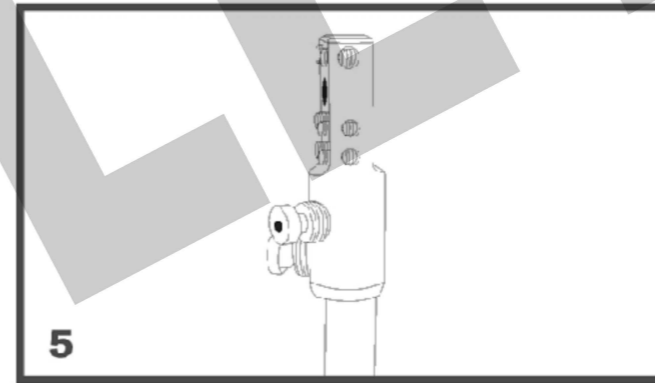

5 Position first bolted lug onto the conductor with shear heads facing out

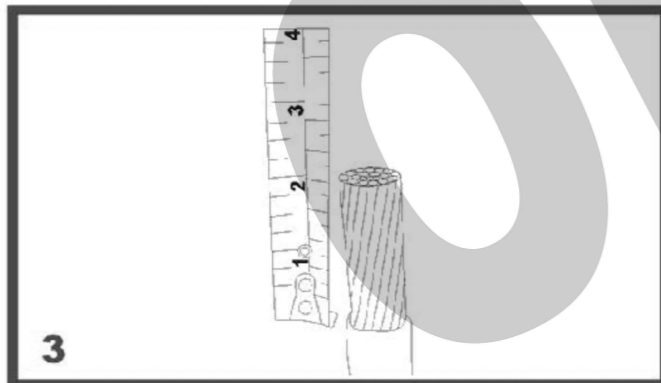

3 Strip top of the conductor 50mm and remove insulation

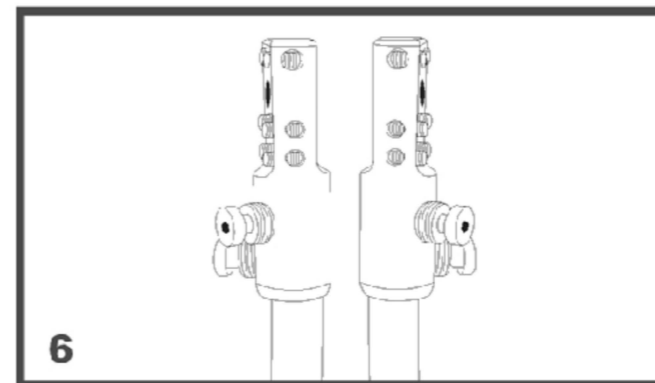

6 Position second lug onto the conductor with the shear heads facing out

NO	DESCRIPTION	DRN	DATE	CKD	APPD
1	OBSOLETE	A.N.	JUL '21	C.C.C.	B.V.
0	ISSUED FOR CONSTRUCTION	J.C.	NOV '07	B.C.	S.C.
AMENDMENTS					

PowerWater
NORTHERN TERRITORY

DES	B.C.
DRN	J.C.
CKD	B.C.
APPD	S.C.
SCALE	N.T.S.
ISSUED	NOV '07
ALL DIM. IN	mm
DRAFTING STANDARD TO A.S.1100	

**2 WAY URD BOLTED CONNECTION
ASSEMBLY INSTRUCTIONS
SHEET 1 OF 4**

A3 DRAWING NUMBER **S02-01-03-15_1**

CAD PRODUCT - DO NOT AMEND MANUALLY



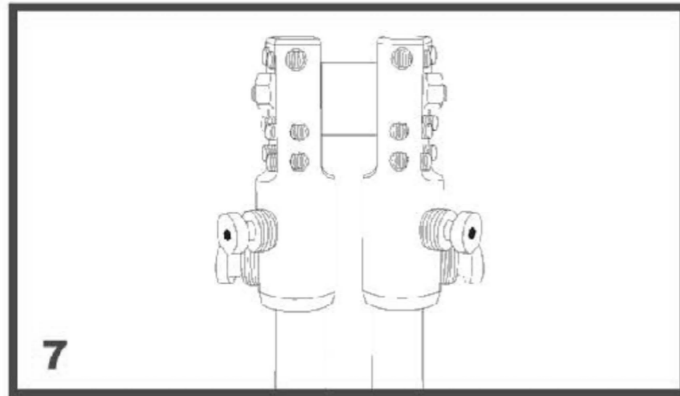

Position busbar into the slot provided between the two bolted lugs ensuring busbar is flush with the lugs. Insert the stainless steel bolts through the lugs and busbar. Make sure the belleville washer is placed on both ends of the bolt with the concave side of the washer facing in.

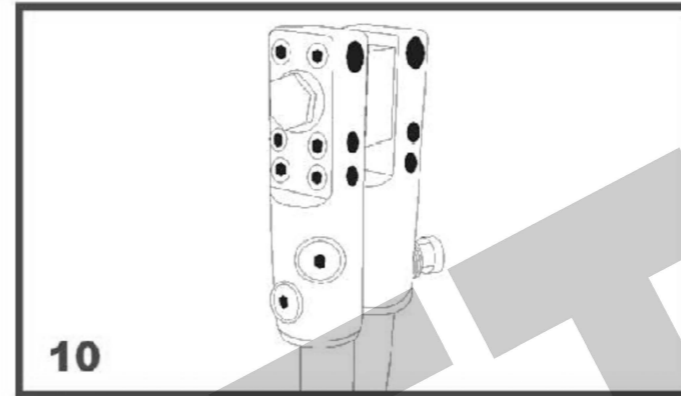

Shear off connection screws making sure you do one lug at a time starting from top to bottom. Make sure there is no bare aluminium conductor visible

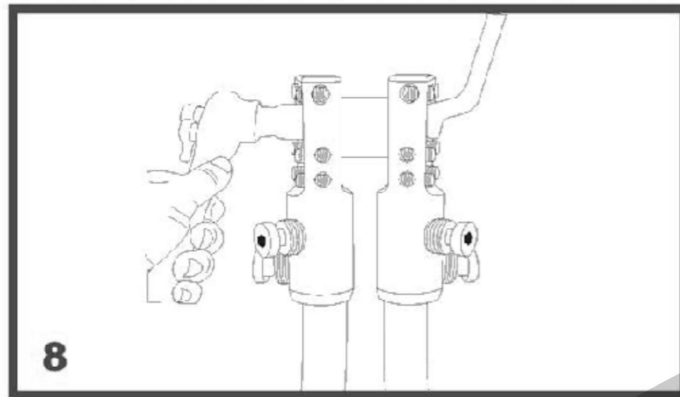

Tighten nut onto bolt with a 19mm spanner and the 19mm socket attached to the ratchet drive. These are in the tool kit.

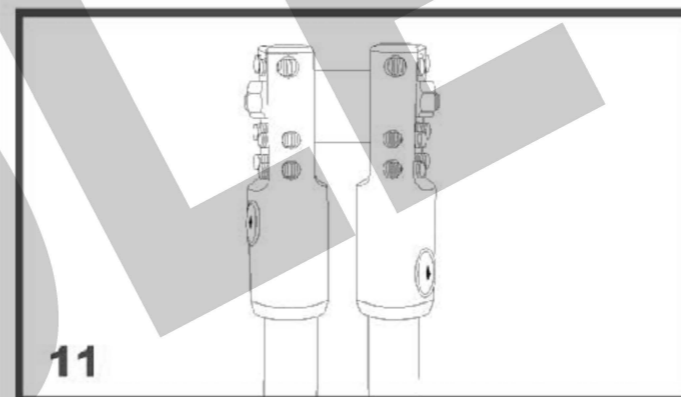

Repeat step above on the second lug making you shear off the screws from top to bottom making sure there is no bare conductor showing.

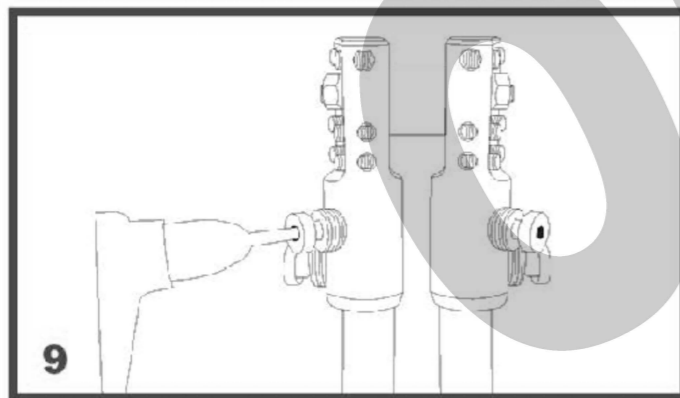

Using the hex socket tool attachment and ratched, tighten connection screws until shear torque is reached.

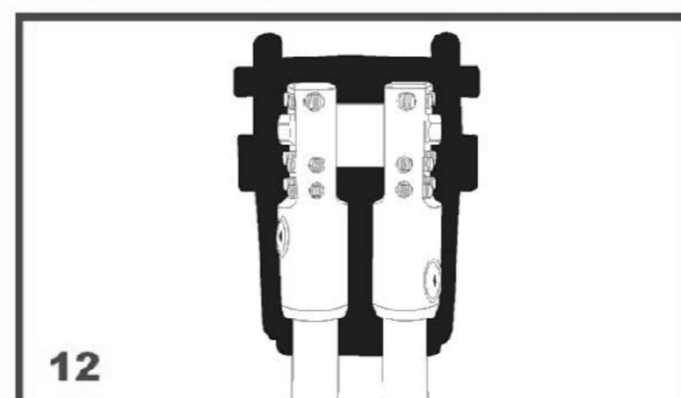

Place the black cover with no service holes onto the side of the lug, the cover will not fit unless screws are sheared off prior

NO	DESCRIPTION	DRN	DATE	CKD	APPD
1	OBSOLETE	A.N.	JUL '21	C.C.C.	B.V.
0	ISSUED FOR CONSTRUCTION	J.C.	NOV '07	B.C.	S.C.
AMENDMENTS					

PowerWater
NORTHERN TERRITORY

DES	B.C.
DRN	J.C.
CKD	B.C.
APPD	S.C.
SCALE	N.T.S.
ISSUED	NOV '07
ALL DIM. IN	mm
DRAFTING STANDARD TO A.S.1100	

**2 WAY URD BOLTED CONNECTION
ASSEMBLY INSTRUCTIONS
SHEET 2 OF 4**

A3 DRAWING NUMBER **S02-01-03-15_2**

CAD PRODUCT - DO NOT AMEND MANUALLY



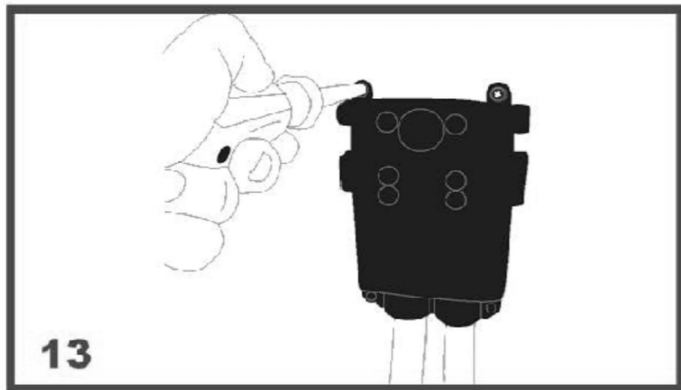

Place front cover onto the back of the lugs and tighten all 4 captive screws using a number 2 Phillips head screwdriver. Screws need to be tightened gradually and sequentially to allow for the captive screws.

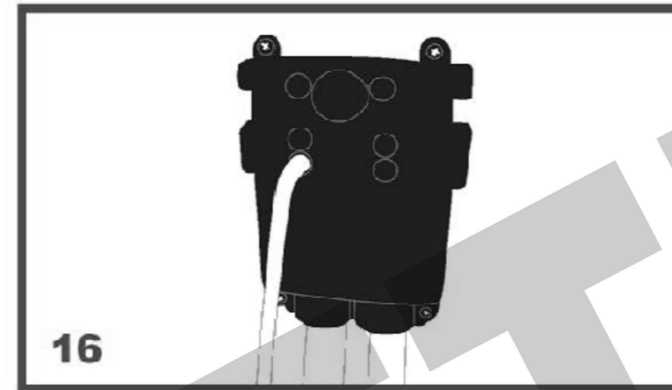

Then tighten both grub screws and pull service cable to ensure it is inserted correctly

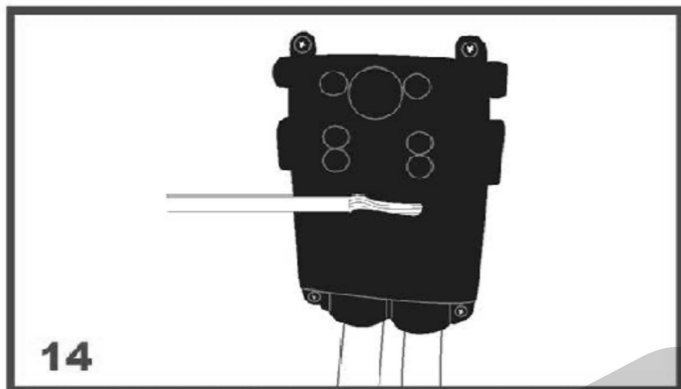

Strip service cable to length specified on the front cover, up to 70mm² compacted conductor can be used

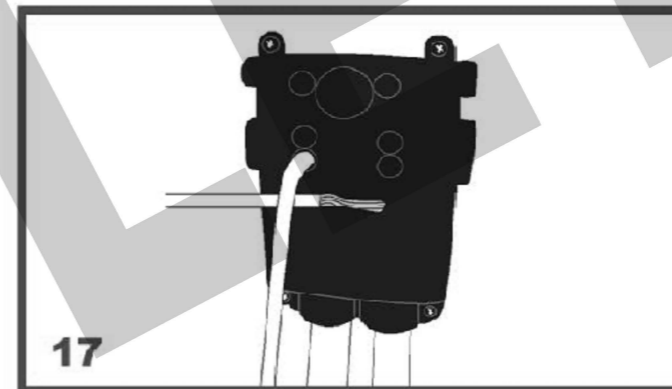

Install cross the road or earth cable into upper port which can take up to 70mm² compacted cable, strip conductor as per strip length on front cover

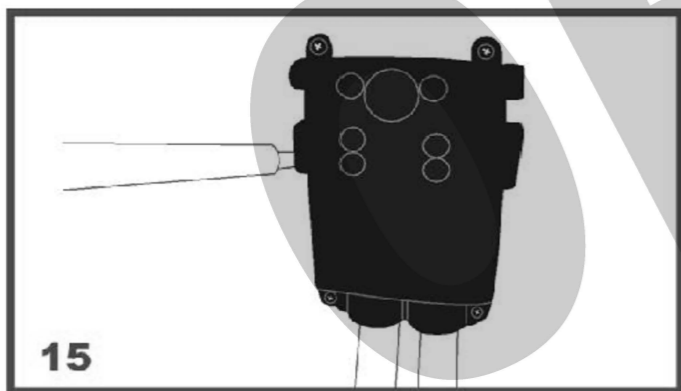

Loosen all required grub screws and insert service cable from the front of the cover. Ensure cable is inserted all the way.

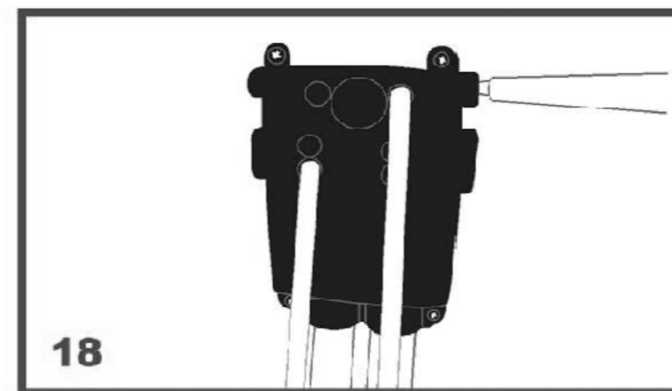

Loosen the required grub screws until the conductor is inserted all the way. Tighten grub screws ensuring there is no bare conductor visible. Pull cable to ensure it is inserted correctly.

NO	DESCRIPTION	DRN	DATE	CKD	APPD
1	OBSOLETE	A.N.	JUL '21	C.C.C.	B.V.
0	ISSUED FOR CONSTRUCTION	J.C.	NOV '07	B.C.	S.C.
AMENDMENTS					

PowerWater
NORTHERN TERRITORY

DES	B.C.
DRN	J.C.
CKD	B.C.
APPD	S.C.
SCALE	N.T.S.
ISSUED	NOV '07
ALL DIM. IN	mm
DRAFTING STANDARD TO A.S.1100	

**2 WAY URD BOLTED CONNECTION
ASSEMBLY INSTRUCTIONS
SHEET 3 OF 4**

A3 DRAWING NUMBER **S02-01-03-15_3**



CAD PRODUCT - DO NOT AMEND MANUALLY



AMDT



CMPBL2 Completed

						DES B.C. DRN J.C. CKD B.C. APPD S.C. SCALE N.T.S.		2 WAY URD BOLTED CONNECTION ASSEMBLY INSTRUCTIONS SHEET 4 OF 4				
1	OBSOLETE	A.N.	JUL '21	C.C.C.	B.V.	 PowerWater NORTHERN TERRITORY	ISSUED	NOV '07	A3	DRAWING NUMBER	S02-01-03-15_4	 1 AMDT
0	ISSUED FOR CONSTRUCTION	J.C.	NOV '07	B.C.	S.C.		ALL DIM. IN mm	DRAFTING STANDARD TO A.S.1100				
AMENDMENTS												