

ITEM 1 STEEL SUPPORT CHANNEL STRUT 41 x 41

ITEM NUMBER 8680
Scale 1 : 1

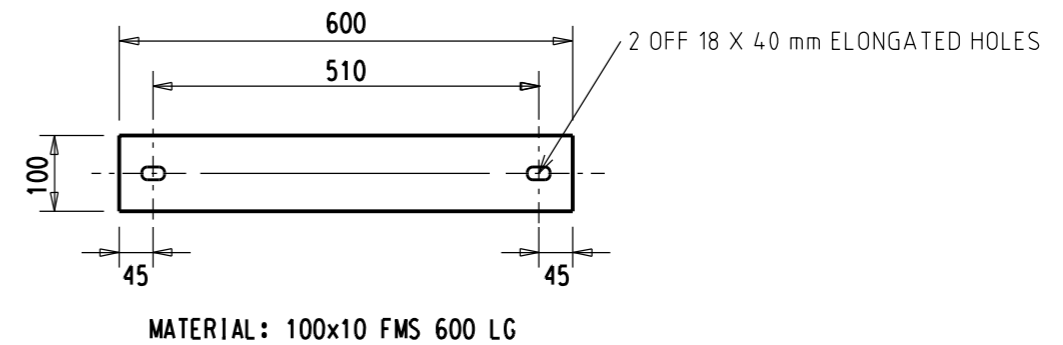

ITEM 2 CROSSARM MOUNTING SPACER FOR WELDED CONSTRUCTION (FMS)

ITEM NUMBER 9274
Scale 1 : 10

NOTES:

- ITEM 2 CAN BE USED FOR INSTALLATION OF UNIVERSAL FIBREGLASS REINFORCED POLYMER CROSSARM (STD DRW No S01-01-02-21) AND ALL HV/LV DURAGAL CROSSARMS ON THE WELDED CONSTRUCTION.
- IF APPLICABLE 2 x 18 DIA HOLES TO MATCH THE MOUNTING HOLES ON ITEM 2 ARE TO BE DRILLED IN THE CROSSARM BY FIELD CREW.

						DES .		POWER STANDARD DRAWING	
						DRN G.R.		LINE HARDWARE	
						CKD PMC		BRACKETS	
						APPD C.H.Y.		UNIVERSAL ARM MOUNTING BRACKET	
						SCALE AS SHOWN.		(WELDED CONSTRUCTION) AND UNISTRUT	
						ISSUED FEB '94		A3	DRAWING NUMBER S01-01-04-06
						ALL DIM. IN mm			
						DRAFTING STANDARD TO A.S.1100		CAD PRODUCT - DO NOT AMEND MANUALLY	
11	UPDATE DRAWING TITLE, DESCRIPTION & HOLE DETAILS ITEM 2, & ITEM 1	A.N.	JAN'21	B.V.	B.C.	 NORTHERN TERRITORY			
10	DIMENSIONS AND DESCRIPTION. OBSOLETE ITEMS REMOVED AND NOTES UPDATED	H.E.	APR'20	B.C.	H.E.				
NO	DESCRIPTION	DRN	DATE	CKD	APPD				
AMENDMENTS									