

**ITEM 1: BALL HOOK-LONG SHANK - 70kN**  
 REF 70BHL AS 1154.1  
 MATERIAL - FORGED STEEL - 500 MPa  
 ITEM NUMBER 415320

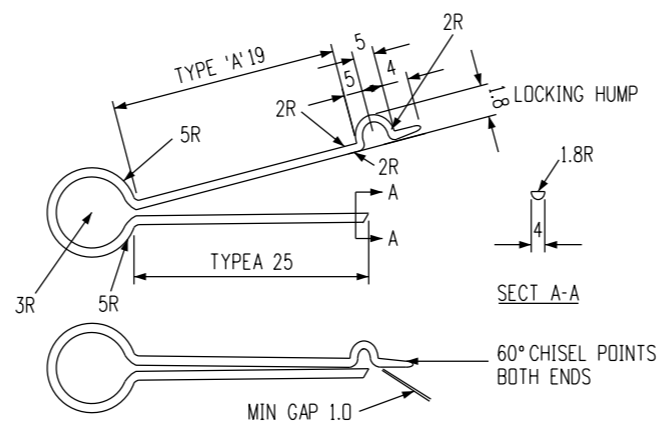

**ITEM 2: HUMPBACK SPLIT PIN REF HP/A**  
 MATERIAL - STAINLESS STEEL  
 COLD ROLLED & COLD FORMED  
 NOTE - SUITABLE FOR PINS OR BOLTS  
 Ø16 TO Ø20  
 ITEM NUMBER 3160

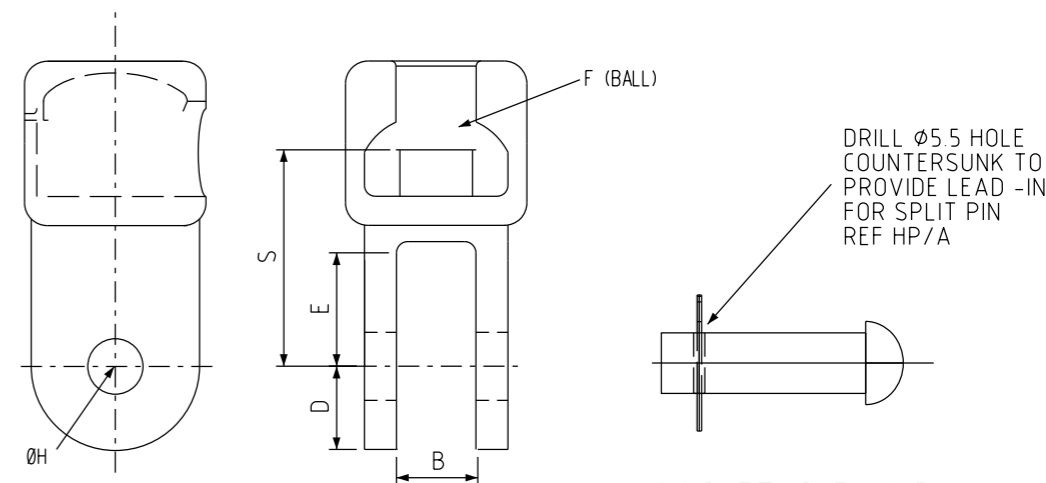

**ITEM 3: SOCKET CLEVIS**  
 (TO BE SUPPLIED WITH PIN REF 16/P)  
 MATERIAL - MALLEABLE CAST IRON  
 NOTE - EACH SOCKET - ENDED  
 FITTINGS IS TO BE SUPPLIED  
 WITH SECURITY CLIP TO SUIT  
 (SEE DRG S01-01-04-03)  
 INSERTED IN THE SOCKET

**SOCKET-CLEVIS PIN**  
 SUPPLIED WITH EACH SOCKET-CLEVIS  
 PIN SUPPLIED WITH HUMPBACK  
 SPLIT PIN REF HP/A  
 MATERIAL - FORGED STEEL

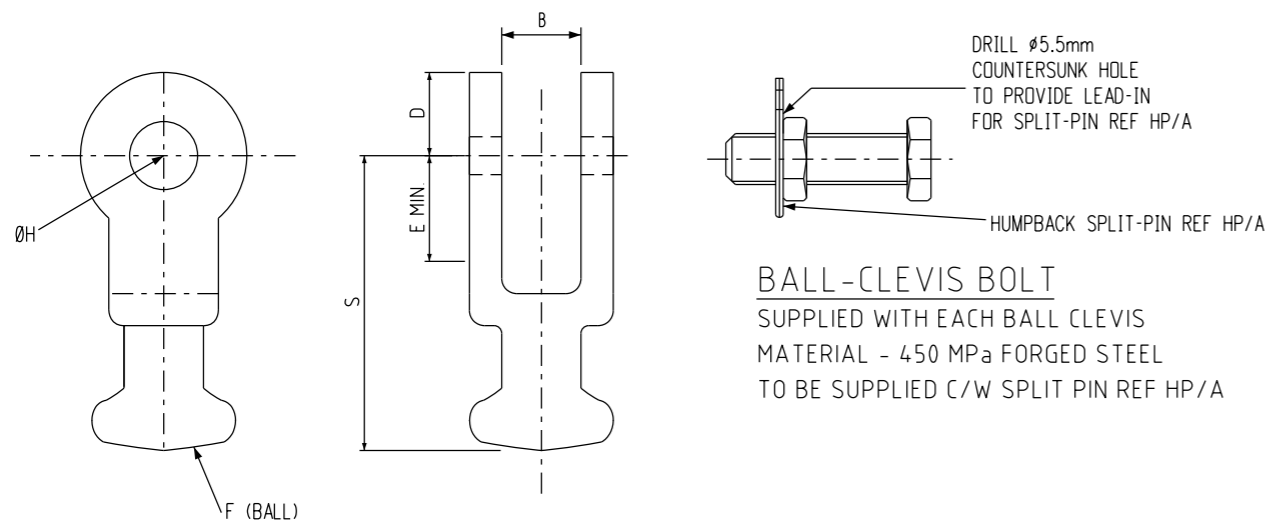

**ITEM 4: BALL-CLEVIS**  
 TO BE SUPPLIED WITH BOLT  
 MATERIAL - FORGED STEEL

**BALL-CLEVIS BOLT**  
 SUPPLIED WITH EACH BALL CLEVIS  
 MATERIAL - 450 MPa FORGED STEEL  
 TO BE SUPPLIED C/W SPLIT PIN REF HP/A

**NOTES:**

- ALL FITTINGS TO COMPLY WITH AS 1154.1 AS PER TABLE AND ITEM DESCRIPTION.
- REFER TO STSP 01-018 FOR MORE INFORMATION.
- 'Y' CLEVIS TO BE NOMINALLY 45° ANGLE. DIMENSION 'B' IS FROM THE OPEN EDGES.

**TABLE 1: FITTING ATTRIBUTES**

ITEM REF.	ITEM NUMBER	TYPE	STRENGTH RATING	NOMINAL DIMENSIONS							AS 1154.1 REF.
				B	D	E	F	H	S	BOLT/PIN DIA.	
3	12120	SOCKET - CLEVIS	70kN	20	22	28	16	18	59	16	70SC
	235275	SOCKET - CLEVIS	160kN	24	24	35	20	22	62	20	160SC
	504099	SOCKET - CLEVIS	310kN	28	32	52	24	26	82	24	-
4	3137	BALL - CLEVIS	70kN	20	22	28	16	18	78	16	70BC
	283945	BALL - CLEVIS	160kN	24	24	35	20	22	95	20	160BC
	504084	BALL - 'Y' CLEVIS	160kN	67	24	40	24	22	85	24	-

NO	DESCRIPTION	DRN	DATE	CKD	APPD
8	UPDATED ITEM 1, 3 & 4 DETAILS, TITLE, FORMATTING, STANDARDS & CHANGED 'STOCK CODE' TO 'ITEM NUMBER'. ADDED TABLE AND NOTES 2 & 3	A.N.	AUG'21	A.N.	B.V.
7	TITLEBLOCK & DRAWING NUMBER FORMATTED	K.T.	DEC'18	C.C.	C.C.
6	REDRAWN IN CAD	C.C.	NOV'10	A.T.	S.C.
AMENDMENTS					



DES	A.TALYOR	POWER STANDARD DRAWING			
DRN	C.COPPINS	LINE HARDWARE INSULATOR FITTINGS SUSPENSION			
CKD	A.TALYOR				
APPD	A.TALYOR				
SCALE	N.T.S.	A3	DRAWING NUMBER	S01-01-04-02	
ISSUED	NOV'10			DRAWING NUMBER	
ALL DIM.	IN mm	DRAFTING STANDARD TO A.S.1100		CAD PRODUCT - DO NOT AMEND MANUALLY	

