

FRONT VIEW WISHBONE CONSTRUCTION  
(VERSION RIGHT HAND)

SCALE 1:25 ITEM NUMBER: 504921

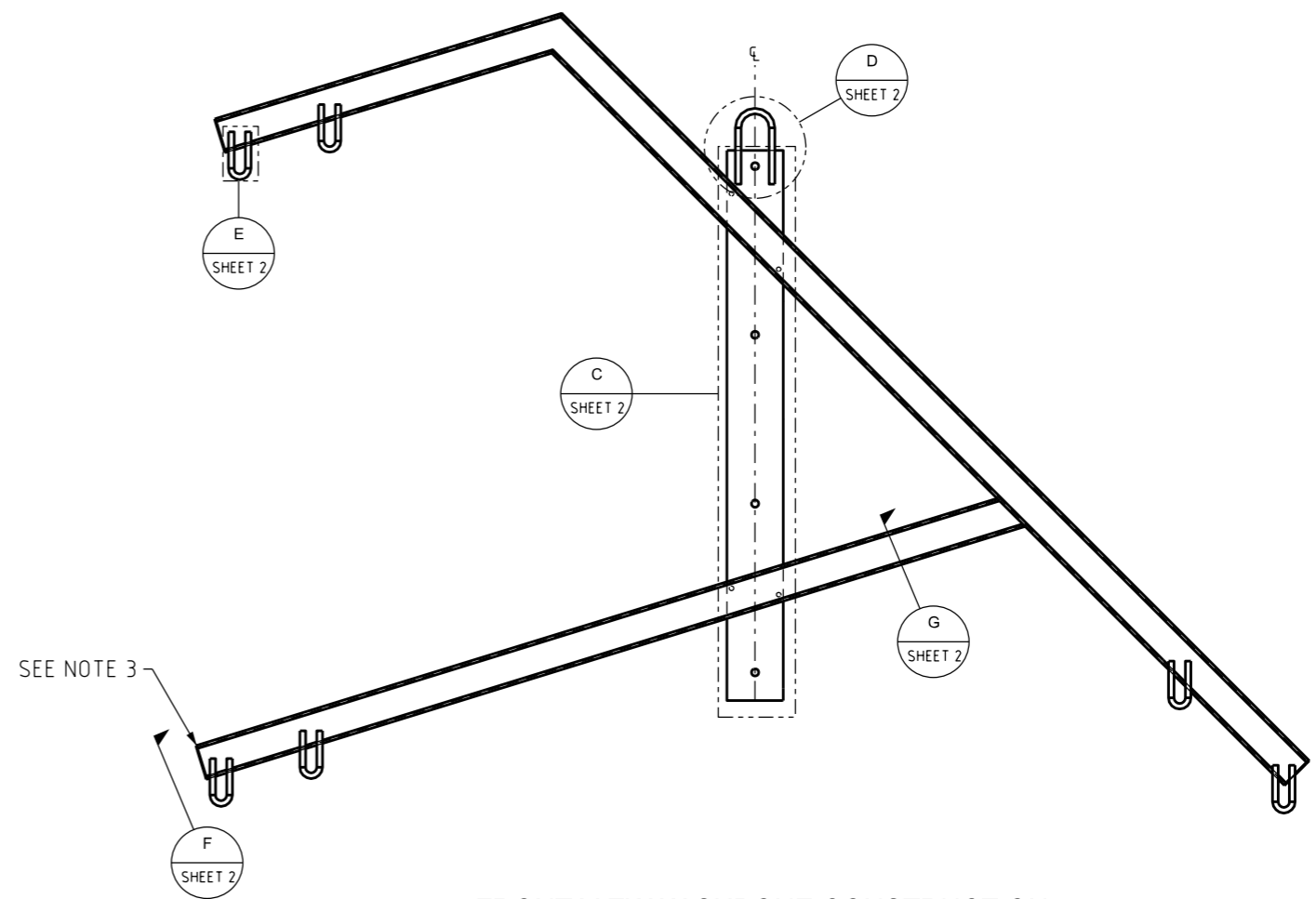

FRONT VIEW WISHBONE CONSTRUCTION  
(VERSION LEFT HAND)

SCALE 1:25 ITEM NUMBER: 504920

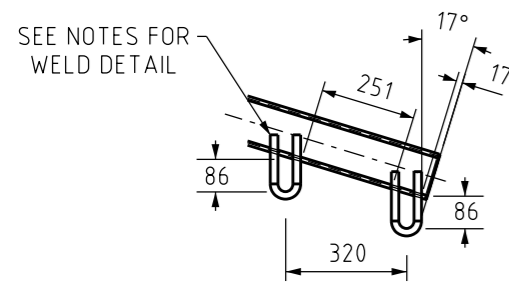

DETAIL A  
SCALE 1:20

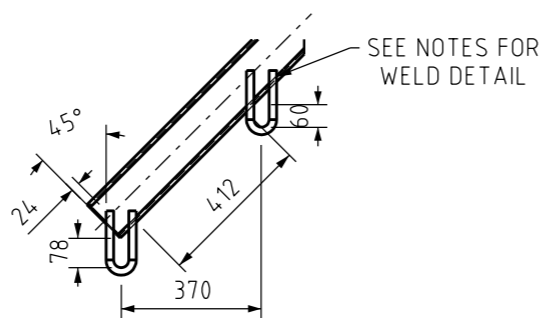

DETAIL B  
SCALE 1:20

**WISHBONE CONSTRUCTION NOTES:**

1. MATERIAL : 125 x 75 x 5 RHS
2. ALL STEEL TO BE GRADE 350
3. CROSSARM ENDS SHALL BE CAPPED WITH WELDED ON 5MM THICK (MINIMUM) STEEL PLATE.
4. ALL WORKMANSHIP AND MATERIALS SHALL BE IN ACCORDANCE WITH AS 3678 & POWER AND WATER SPECIFICATION STSP 01-002
5. ALL WELDING AND WELD PREPARATION SHALL BE IN ACCORDANCE WITH AS 1554. FILLET & BUTT WELDS TO BE 6MM UNLESS NOTED OTHERWISE.
6. ALL ROUGH OR BURRED EDGES ARE TO BE DRESSED CLEAN.
7. CROSSARM TO BE HOT DIP GALVANIZED.

NO	DESCRIPTION	DRN	DATE	CKD	APPD
2	WISHBONE CROSSARM REDESIGNED WITH AMENDED DIMENSIONS, BACKING PLATE & TWO VERSIONS. TITLE UPDATED & SHEET 2 ADDED	C.C.	AUG'22	B.V.	B.C.
AMENDMENTS					



POWER STANDARD DRAWING			
DES	-	CROSSARM	
DRN	PMC	66kV WISHBONE ARRANGEMENT	
CKD	N.S.	FOR UNIVERSAL POLE CONSTRUCTION	
APPD	B.T.K.	(SHEET 1 OF 2)	
SCALE	AS SHOWN	A3	DRAWING NUMBER S10-01-02-01_1
ISSUED	JUL'90		
ALL DIM. IN mm		CAD PRODUCT - DO NOT AMEND MANUALLY	
DRAFTING STANDARD TO A.S.1100		AMDT	

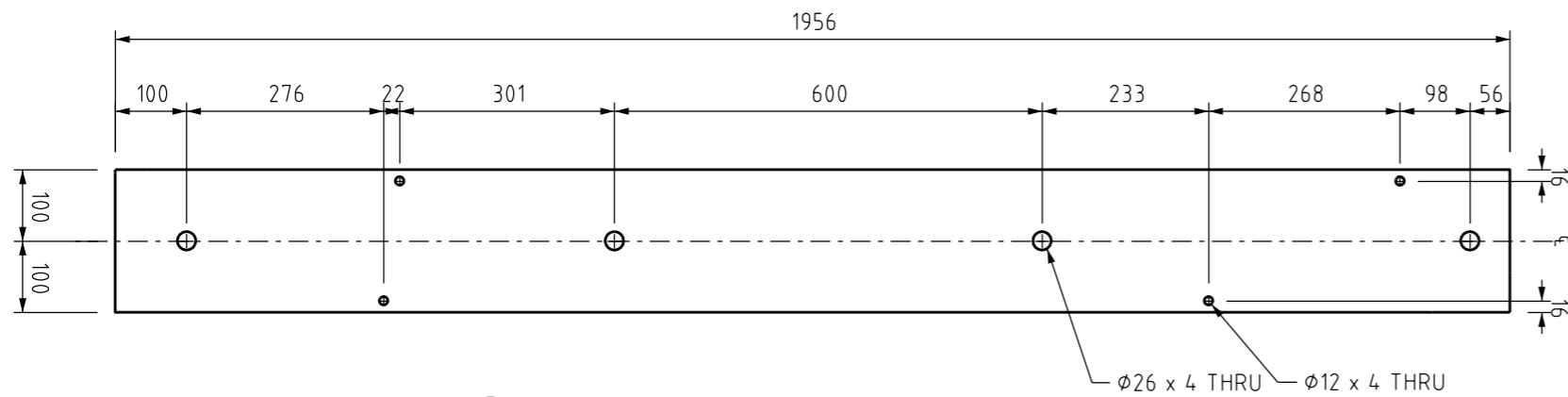

**C MOUNTING PLATE FRONT VIEW**  
 SCALE 1:10 MATERIAL : 200 x 12 PLATE

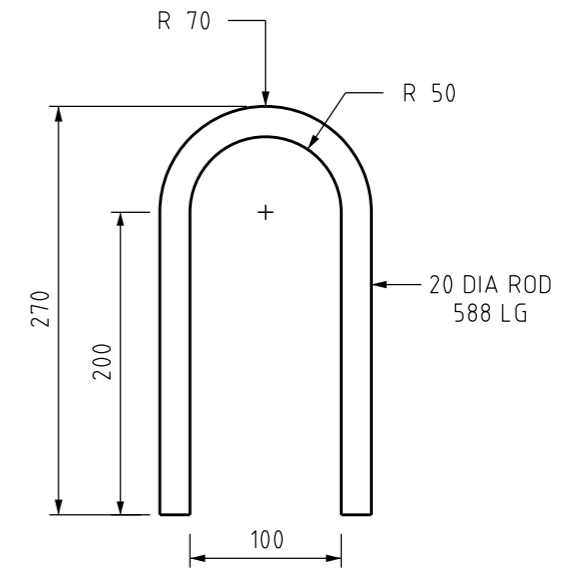

**D ROUND U BEND LIFTING POINT FRONT VIEW**  
 SCALE 1:5 MATERIAL: 20 DIA ROD

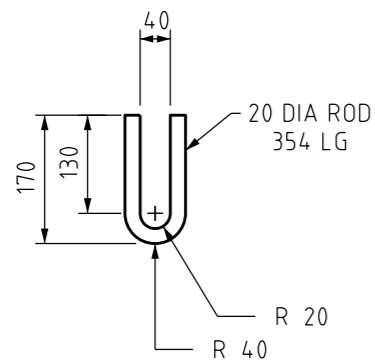

**E ROUND U BEND FRONT VIEW**  
 SCALE 1:10 MATERIAL: 20 DIA ROD

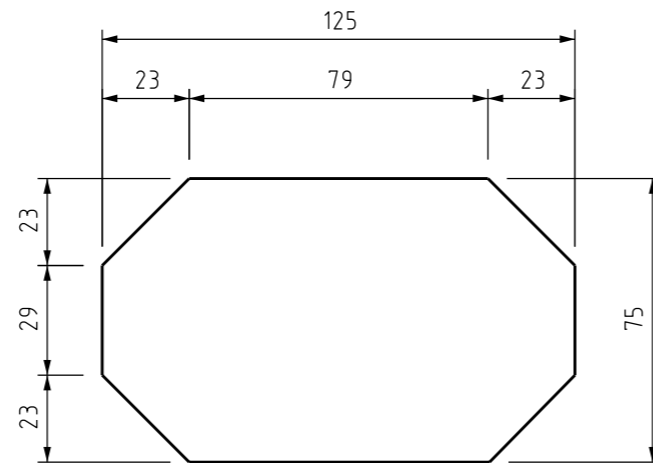

**F F END CAP DETAIL**  
 SCALE 1:2 MATERIAL : 5mm THICK MINIMUM

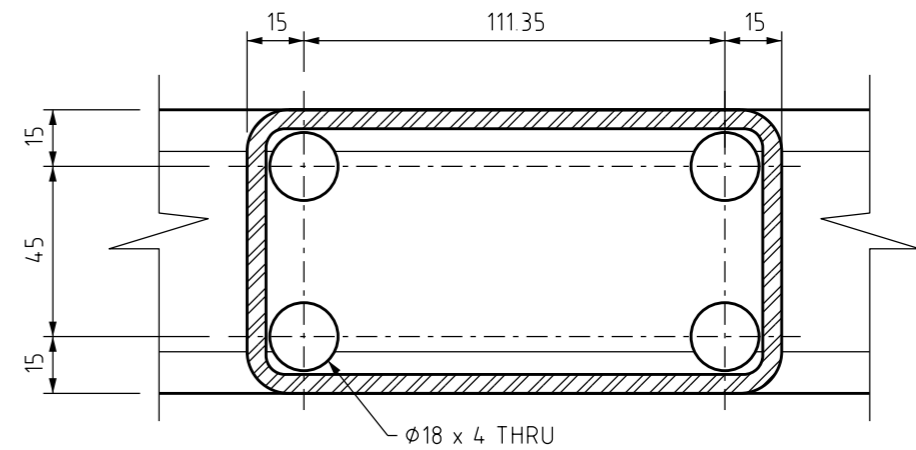

**G G SECTION DETAIL**  
 SCALE 1:2

0	ISSUED FOR CONSTRUCTION	C.C.	AUG-22	B.V.	B.C.
NO	DESCRIPTION	DRN	DATE	CKD	APPD
AMENDMENTS					



DES -	POWER STANDARD DRAWING		
DRN PMC	CROSSARM		
CKD N.S.	66kV WISHBONE ARRANGEMENT		
APPD B.T.K.	FOR UNIVERSAL POLE CONSTRUCTION		
SCALE AS SHOWN	(SHEET 2 OF 2)		
ISSUED JUL '90	A3	DRAWING NUMBER	S10-01-02-01_2
ALL DIM. IN mm			
DRAFTING STANDARD TO A.S.1100		CAD PRODUCT - DO NOT AMEND MANUALLY	

