

M24 THREAD
x 175 LG
C/W GALVANISED
NUTS x 2
WASHERS x 2
& SPRING WASHER

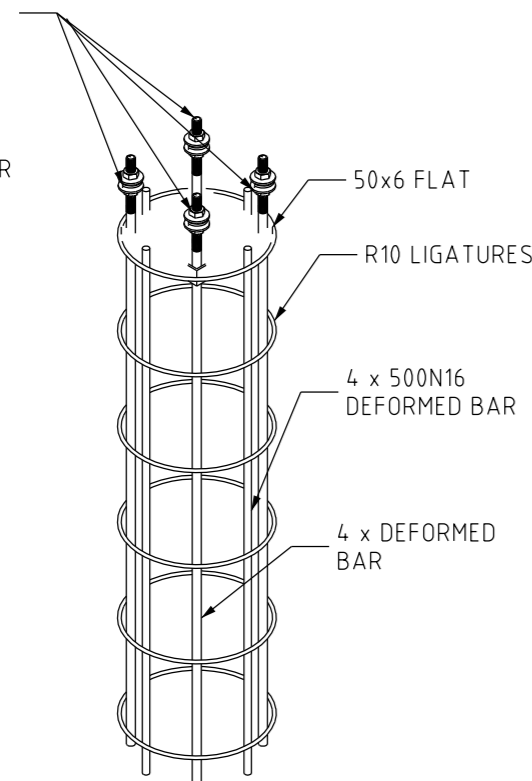

ISOMETRIC VIEW

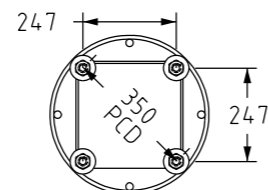

TOP VIEW

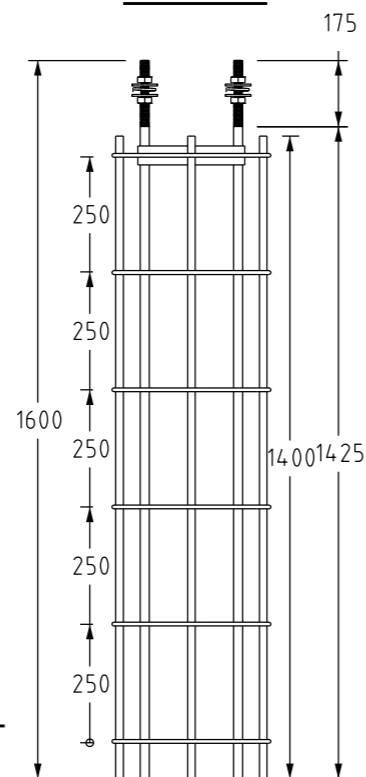

ELEVATION

TYPE APPLICATION

ITEM 1: TYPE 12 - FOR USE WITH 12.0 METRE SINGLE AND DOUBLE OUTREACH TAPERED STEEL COLUMN.

ITEM 2: TYPE 18 - FOR USE WITH 18.0 METRE OUTREACH TAPERED STEEL COLUMN.

REFERENCE DRAWINGS

S03-01-02-01 - RAG BOLT REINFORCEMENT TYPE 5 AND TYPE 9

S03-01-02-03 - TAPERED STEEL COLUMNS, FOUNDATION ARRANGEMENTS

S03-01-02-06 - RAG BOLT REINFORCEMENT, BAR - DEFORMED

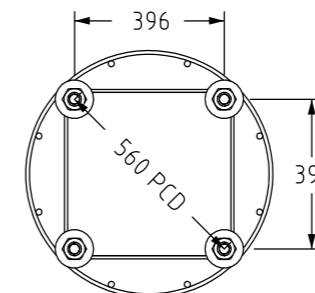

TOP VIEW

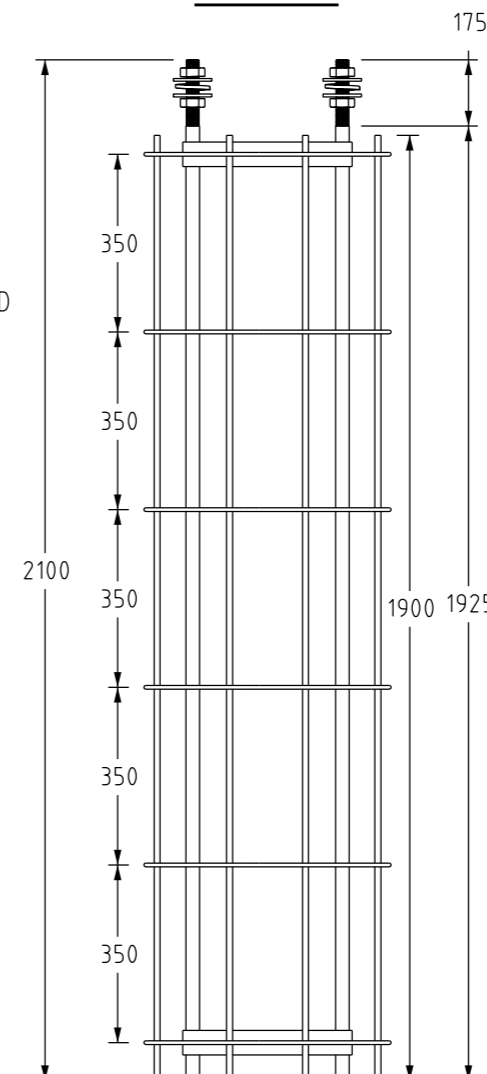

ELEVATION

M36 THREAD
x 175 LG
C/W GALVANISED
NUTS x 2
WASHERS x 2
& SPRING WASHER

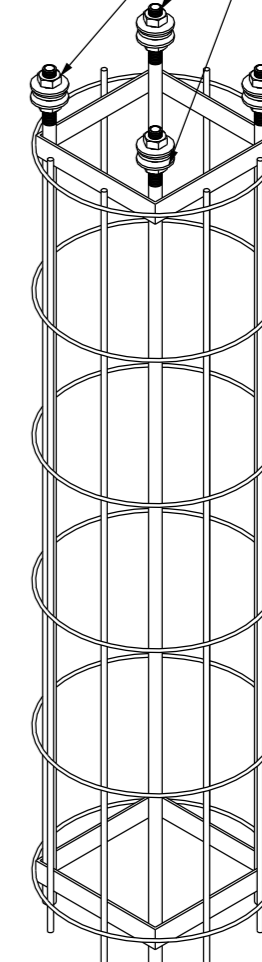

ISOMETRIC VIEW

ITEM 1 RAG BOLT REINFORCEMENT ASSEMBLY TYPE 12

(ITEM NUMBER - 11825)

NOTES

- ALL WORKMANSHIP AND MATERIALS SHALL BE IN ACCORDANCE WITH AS3679 Pt1 AND AS/NZS 4671
- ALL WELDING AND WELD PREPARATION TO BE TO AS1554. FILLET WELDS TO BE 6mm UNLESS NOTED OTHERWISE.
- RAG BOLTS SHALL BE GRADE 500N DEFORMED BARS MINIMUM 175mm THREAD (TO AS1275) SHALL BE CUT IN TO DEFORMED BARS
- PITCH CIRCLE DIAMETER (P.C.D.) OF RAG BOLTS IS CRITICAL.
- THE 175mm THREADED SECTION OF THE RAG BOLTS TOGETHER WITH THE ASSOCIATED NUTS AND WASHERS SHALL BE HOT DIP GALVANIZED IN ACCORDANCE WITH AS 2312. NUTS AND WASHERS SHALL BE GRADE 8.8 AND AFTER GALVANISING BE FIRM FITTING ON THE THREADED SECTION OF THE RAG BOLTS - IN ACCORDANCE WITH AS 1112, AS 1237 AND AS 1252, AS APPROPRIATE.
- DESIGN OF RAG BOLT REINFORCEMENT FOUNDATION IS BASED ON SOIL WHICH HAS A SHEAR STRENGTH OF NOT LESS THAN 200kPa i.e., COMPACT MEDIUM CLAY, WELL BONDED SANDY LOAM, BONDED SAND AND GRAVEL WITH REASONABLE SURFACE WATER DRAINAGE (OR CONDITIONS BETTER THAN DESCRIBED). ANY SOIL CONDITIONS HAVING A SHEAR STRENGTH OF LESS THAN 200kPa i.e., SOFT CLAY, POOR COMPACTED SAND AND SOILS THAT TEND TO ABSORB LARGE AMOUNTS OF WATER, WILL REQUIRE SPECIAL FOUNDATION DESIGN OF LARGER DIMENSION.

ITEM 2 RAG BOLT REINFORCEMENT

ASSEMBLY TYPE 18

(ITEM NUMBER - 11841)

NO	DESCRIPTION	DRN	DATE	CKD	APPD
17	ROLLBACK ON DEFORMED BARS SIZE.	J.R	DEC'23	B.C.	B.V.
16	DEFORMED BARS SIZE UPDATED.	P.BH.	MAR'23	B.C.	B.V.
15	TITLEBLOCK & DRAWING NUMBERS FORMATTED	K.T.	FEB'19	C.C.	C.C.
14	REFERENCE TO "ROD" REMOVED.	A.B.	APR'10	A.T.	S.C.
13	UPDATED TO AS/NZS 4671 & REDRAWN	J.C.	JUL'09	A.T.	S.C.
AMENDMENTS					



DES	S.D.T&M	POWER STANDARD DRAWING		
DRN	J.C.	RAG BOLT REINFORCEMENT TYPE 12 AND TYPE 18 FABRICATION DETAILS		
CKD	T.GOODIE			
APPD	B.T.KENT			
SCALE	1:20			
ISSUED	19.11.87	A3	DRAWING NUMBER	S03-01-02-02
ALL DIM.	IN mm			
DRAFTING STANDARD TO A.S.1100		CAD PRODUCT - DO NOT AMEND MANUALLY		AMDT