

TOP VIEW
1:10

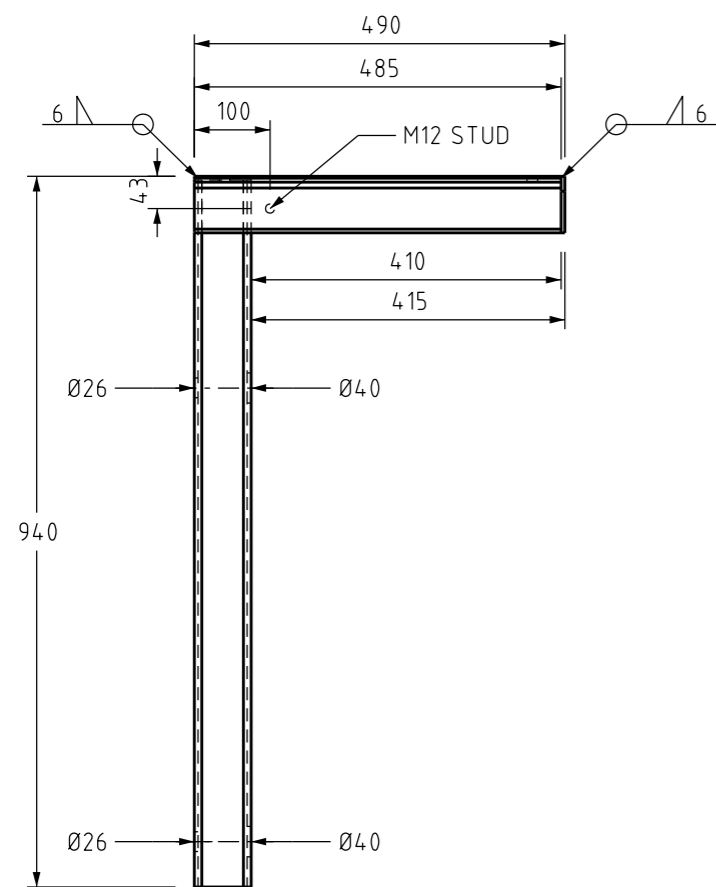

FRONT VIEW
1:10

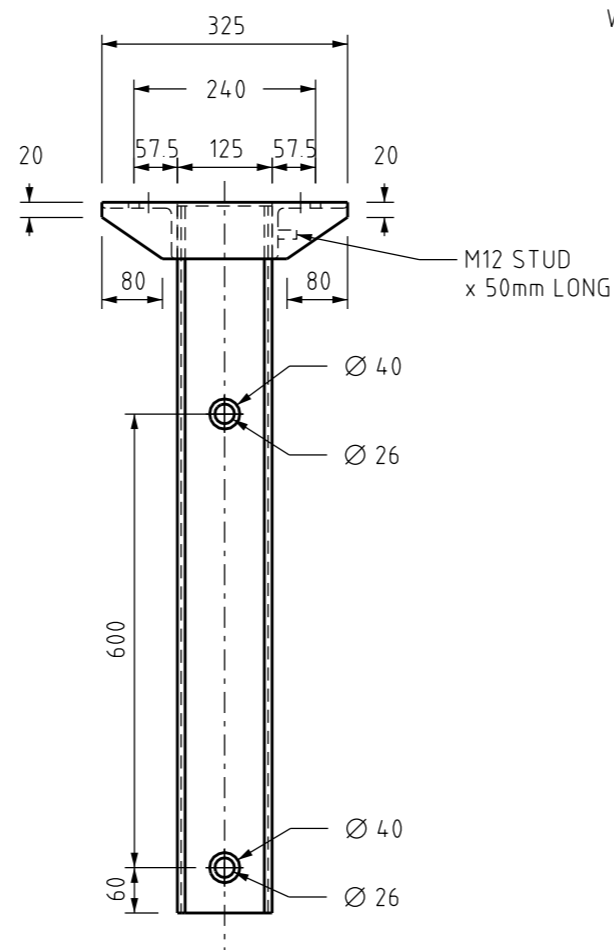

SIDE VIEW
1:10

5mm CAP PLATE FULLY WELDED TO TOP AND BOTTOM OF RHS, ALLOW FOR WEEP HOLES FOR GALVANISING

6mm CONTINUOUS FILLET SHOP WELD ALL AROUND ANGLE TO RHS

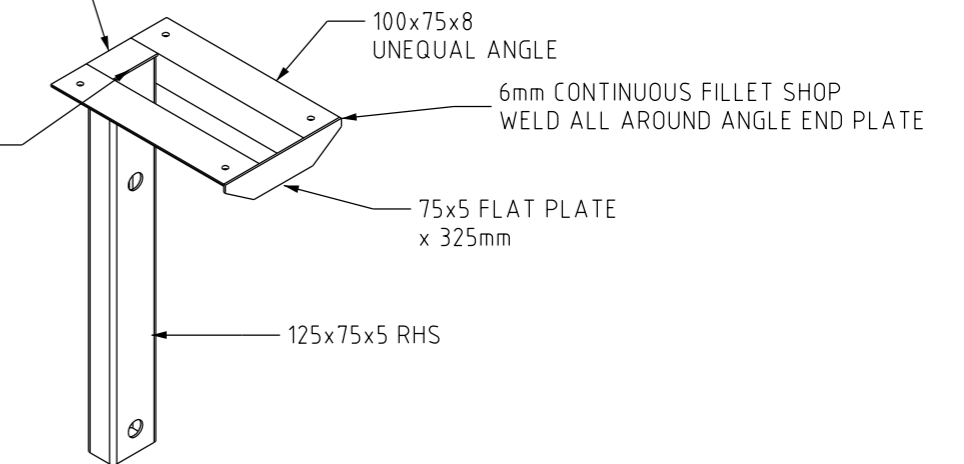

ISOMETRIC VIEW
N.T.S.

NGK GBS TOP MOUNTED BRACKET
ITEM NUMBER:504548

NOTE:

- ALL STEEL TO BE HOT DIP GALVANISED

1 HOLE DIMENSION AMENDED
0 ISSUED FOR CONSTRUCTION

NO	DESCRIPTION	DRN	DATE	CKD	APPD
	AMENDMENTS				

C.C. OCT'20 B.V. B.C.
C.C. MAY'20 B.C. B.V.



DES		POWER STANDARD DRAWING	
DES	B.CHEUNG	NGK GBS TOP MOUNTED BRACKET HOT DIP GALVANISED	
DRN	C.COPPINS	A3	DRAWING NUMBER S01-01-06-19
CKD	B.CHEUNG		
APPD	B.VANDERSTELT	SCALE AS SHOWN	
ISSUED MAY 2020		DRAFTING STANDARD TO A.S.1100	
ALL DIM. IN mm		CAD PRODUCT - DO NOT AMEND MANUALLY	

