

ISOMETRIC VIEW
N.T.S.

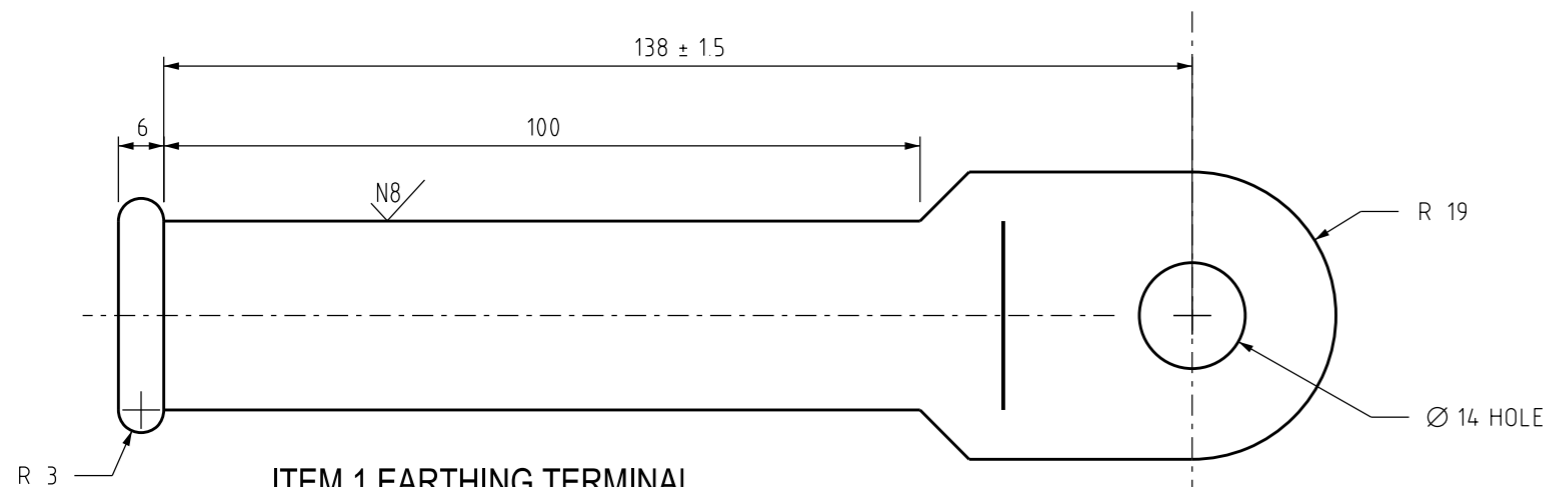

ITEM 1 EARTHING TERMINAL

ITEM NUMBER: 11908
 MATERIAL : ALUMINIUM ALLOY H49.5 (MODIFIED) TO AS1874.
 FINISH : AS CAST UNLESS INDICATED OTHERWISE.
 ALL BURRS AND SHARP EDGES TO BE REMOVED.

TOLERANCE : ±1 mm UNLESS STATED OTHERWISE.

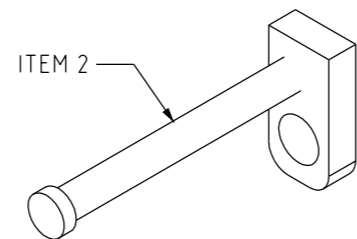
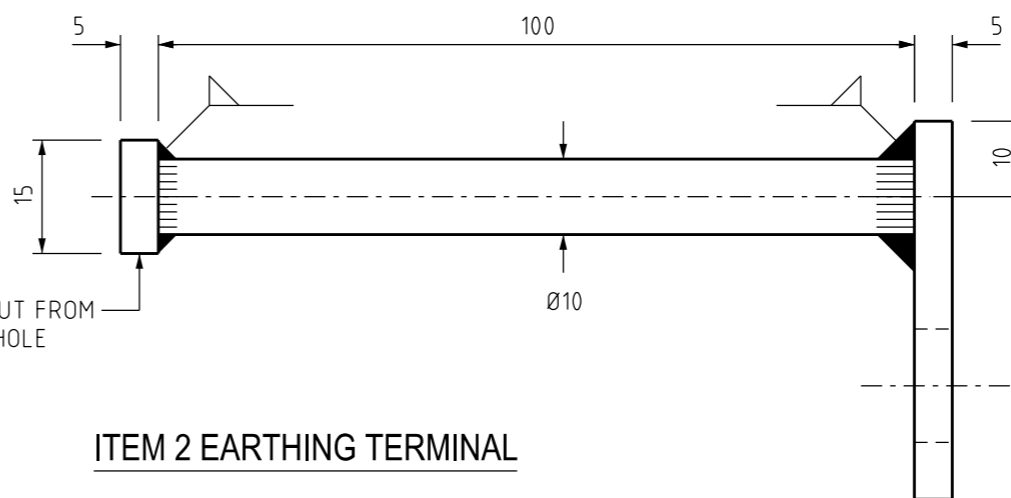

ISOMETRIC VIEW
N.T.S.

ITEM 2 EARTHING TERMINAL

ITEM NUMBER: 402089
 MATERIAL : HOT DIP GALVANISED STEEL
 FINISH : ALL BURRS AND SHARP EDGES TO BE REMOVED.

TOLERANCE : ±1 mm UNLESS STATED OTHERWISE.

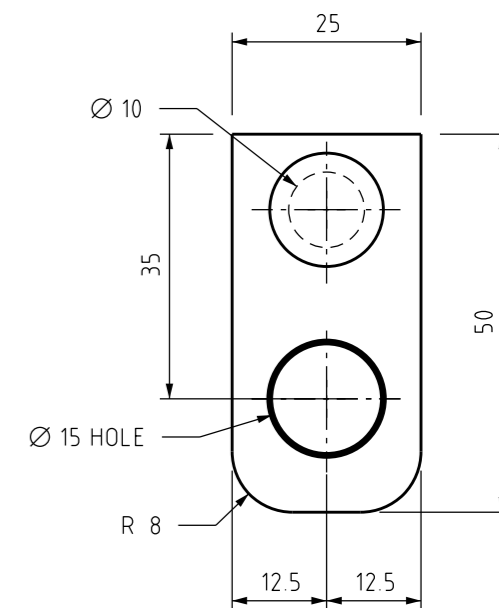

NOTES :

- ALL CASTINGS TO BE CLEARLY MARKED TO IDENTIFY MANUFACTURER.
- ALL UNSPECIFIED RADII TO BE 1.5 mm.

9	UPDATED TO 3D	C.C.	NOV'19	B.V.	B.V.
8	TITLEBLOCK & DRAWING NUMBER FORMATTED	K.T.	DEC'18	C.C.	C.C.
7	ITEM 2 STOCK CODE ADDED	A.T.	FEB'13	B.C.	B.C.
6	ITEM 1 DIMENSION CHANGE. 3D IMAGE ADDED	J.C.	JAN'09	A.T.	S.C.
5	ITEM 2 ADDED	A.S.	MAY'04	R.C.	M.B.
4	AUSTRALIAN STANDARD ALTERED. REDRAWN ON MICROSTATION	J.A.L.	DEC'95	-	P.J.D.
3	TITLE AND NUMBER CHANGED	-	JUL'87	-	-
2	ITEM AND STOCK CODE ADDED	-	JAN'87	-	B.K.
NO	DESCRIPTION	DRN	DATE	CKD	APPD
AMENDMENTS					



DES	D.BIRKETT	POWER STANDARD DRAWING		
DRN	D.STUART	EARTHING EARTHING TERMINAL		
CKD	J.HASSENEN			
APPD	T.A.SMITH	A3	DRAWING NUMBER	S01-01-05-03
SCALE	1:1			
ISSUED	MARCH 1984	CAD PRODUCT - DO NOT AMEND MANUALLY		
ALL DIM. IN	mm			
DRAFTING STANDARD TO A.S.1100		AMDT		