

NOTES :

1. ALL WELDS TO BE FPBW UNLESS NOTED OTHERWISE
2. ITEM 11 GREASE SHALL BE APPLIED ON MATING SURFACE BETWEEN TOP AND BOTTOM FLANGE PLATES TO FILL ANY VOIDS.
3. ALL BOLTS SHALL BE M24 X 110 CLASS 8.8 T/B.
5. ALL BOLTS TO BE LUBRICATED WITH ITEM 13 ANTI-FRICTION LUBRICANT BEFORE INSTALLATION.
4. M24 BOLTS SHALL BE TIGHTENED USING NOMINATED IMPACT WRENCH IN THE SEQUENCE SHOWN IN SECTION 1 FIRST TO "SNUG TIGHT" ON FIRST PASS, THEN SEQUENCE REPEATED TO FINAL TENSION UNTIL SQUIRTER WASHER DIMPLES HAVE COMPLETELY SQUASHED AND RELEASED ORANGE SILICON GEL AS PER DETAIL B.
6. B TYPE POLES WILL FIT ON B/C & D TYOE BASES
7. ALL TWO PIECE POLES SHALL BE USED FOR INTER-POLING INSTALLATIONS ONLY.
8. REFER TO S01-02-05-29 FOR FOUNDATION DETAILS, CENTERLINE OF GROUND PLATE SHALL BE AT GROUND LEVEL.
9. UNIVERSAL B/C 2 PIECE POLE BASE LENGTH IN GROUND IS 2500mm
10. ALL BOLT ASSEMBLIES SHALL BE INSPECTED VISUALLY AND ALSO USING 0.13mm FEELER GAUGE BETWEEN ITEM 10 SQUIRTER WASHER AND FLAT WASHER. 3 OUT OF 5 REJECTION TO THE THREAD BETWEEN DIMPLES REQUIRED FOR A PASS.
11. REFER TO S01-04-04-01 'POLE INSTALLATION PROCEDURE - CIVIL WORKS' FOR THEREQUIREMENT AND INSTALLATION OF POLE CONCRETE FOUNDATIONS.

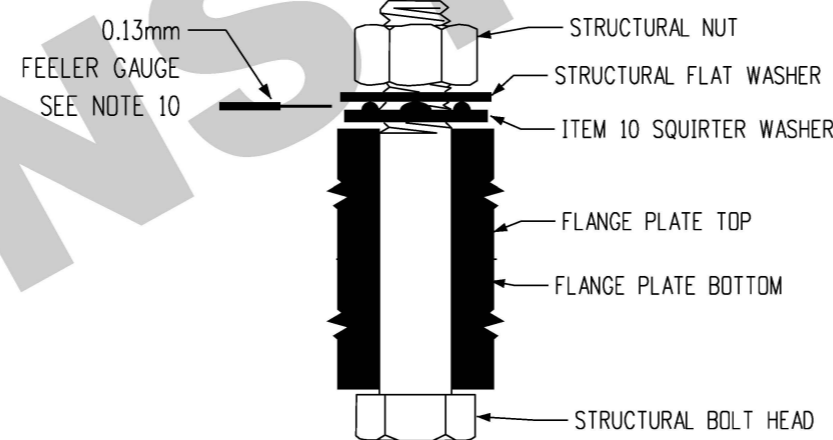

DETAIL B FINAL ORANGE GEL SQUIRT



TYPICAL BOLT HOLE ASSEMBLY

ITEM REF.	QTY	DESCRIPTION	ITEM NUMBER
13	AR	ANTI-FRICTION DRY WAX LUBRICANT	503832
12	1	600 X 450 X 40 CONCRETE PAVER (REFER NOTE 11)	503841
11	AR	HI-LOAD GREASE CARTRIDGE	503788
10	8	M24 TENSION INDICATING SQUIRT WASHER	503616
9	1	15B 2-PIECE POLE TOP	502269
8	1	13.5B 2-PIECE POLE TOP	500495
7	1	12B 2-PIECE POLE TOP	502268
6	1	10.5B 2-PIECE POLE TOP	502267
5	1	9B 2-PIECE POLE TOP	502266
4	1	B/C TYPE 2-PIECE POLE BASE	502265
3	8	M24 FLAT WASHER	412956
2	8	M24x110 GALV. STEEL BOLT CLASS 8.8 C/W NUT	416499
1	2	740 X 430 X 32 FMS, JOINING PLATE, GRADE 250	-
MATERIAL SCHEDULE			

NO	DESCRIPTION	DRN	DATE	CKD	APPD
9	REFORMATTED TABLE. 'NOT FOR NEW CONSTRUCTION' REFER TO S01-01-01-31, S01-01-01-33 & S01-01-01-35 FOR NEW INSTALLATIONS. TITLEBLOCK & DRAWING NUMBERS FORMATTED	A.N.	SEP'21	A.N.	B.V.
8	TITLEBLOCK & DRAWING NUMBERS FORMATTED	K.T.	DEC'18	C.C.	C.C.
7	ITEMS 12, 13 & NOTE 11 ADDED. ITEM 11 & NOTES AMENDED	I.B.	AUG'16	A.T.	I.B.
6	EARTH BOND REMOVED, NOTE 2, 4 & 9 AMENDED, NOTE 10 ADDED, ITEM 10 & 11 ADDED	I.B.	MAR'16	A.T.	I.B.
5	NOTE 9 ADDED	C.C.	JUL'15	I.B.	B.C.



DES	B.DAVIES	POWER STANDARD DRAWING		
DRN	M.MERCADO	POLES B TYPE BOLTED CONNECTIONS FLANGE JOINTED		
CKD	B.REID			
APPD	B.CHEUNG			
SCALE	N.T.S			
ISSUED	JUN'11			
ALL DIM.	IN mm	A3	DRAWING NUMBER S01-01-01-28	9
DRAFTING STANDARD TO A.S.1100		CAD PRODUCT - DO NOT AMEND MANUALLY		AMDT