

SWITCH COVER
5mm THICK ALUMINIUM PLATE

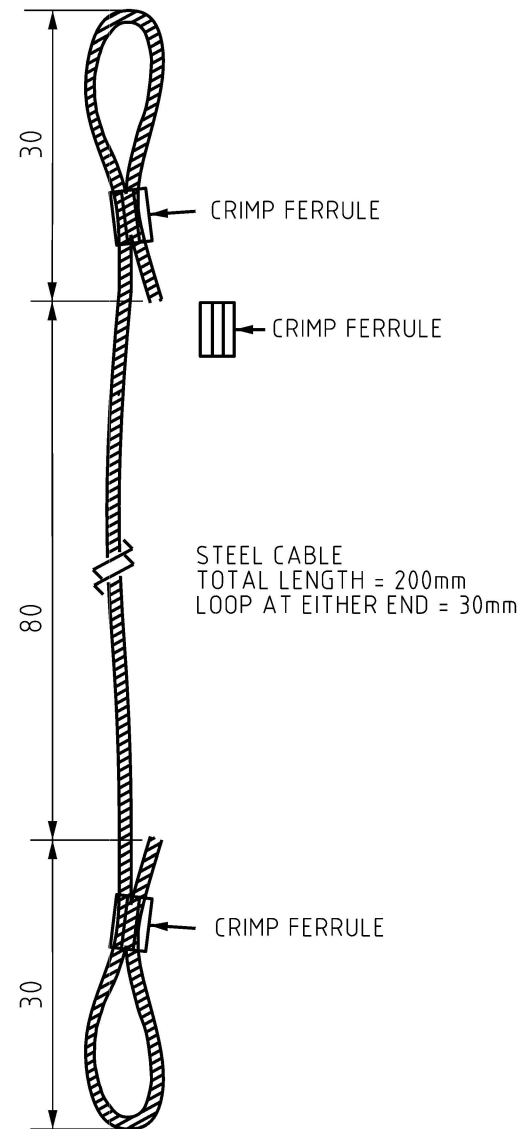

EXAMPLE OF INSTALLED COVER

NOTES:

1. THIS DEVICE IS TO BE USED AS A REPLACEMENT IN THE EVENT WHERE THE ORIGINAL PLASTIC COVER BECOMES BROKEN
2. ALL DIMENSIONS ARE IN MILLIMETRES
3. REMOVE ALL BURRS AND SHARP EDGES
4. A SUITABLE CRIMPING TOOL SHALL BE USED FOR ATTACHING THE FERRULES TO SECURE THE SWITCH COVER

ITEM NUMBER: 504639

NO	DESCRIPTION	DRN	DATE	CKD	APPD
0	ISSUED FOR CONSTRUCTION.	C.C.	AUG'20	H.E.	B.V.
AMENDMENTS					



DES		POWER STANDARD DRAWING	
DES	B.VANDASTELT	SCHNEIDER RM6 RING MAIN UNIT LOCKABLE SWITCH COVER	
DRN	C.McLAREN		
CKD	B.CHEUNG		
APPD	B.CHEUNG		
SCALE	AS SHOWN		
ISSUED	MARCH 2020	A3	DRAWING NUMBER S02-01-04-29
ALL DIM.	IN mm		
DRAFTING STANDARD TO A.S.1100		CAD PRODUCT - DO NOT AMEND MANUALLY	

