

PLAN VIEW  
N.T.S.

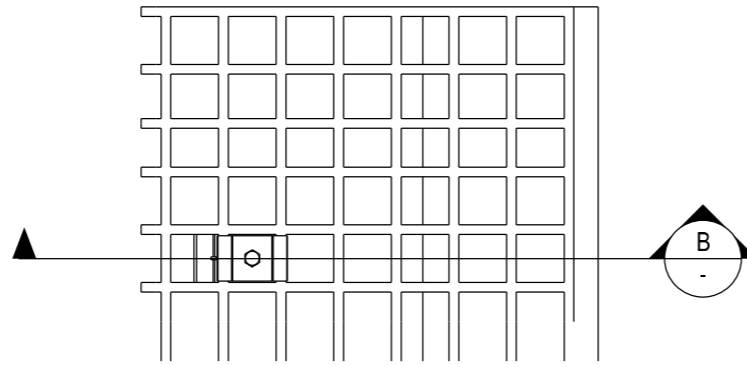

PLAN VIEW  
N.T.S.

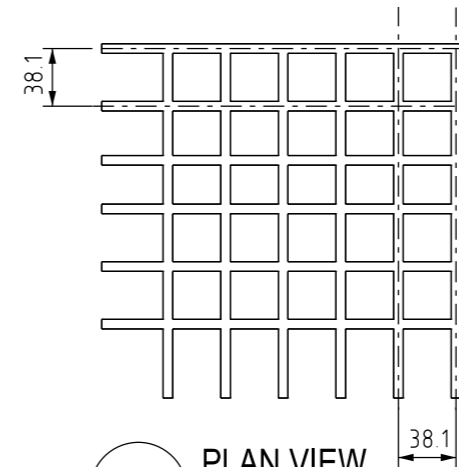

PLAN VIEW  
N.T.S.

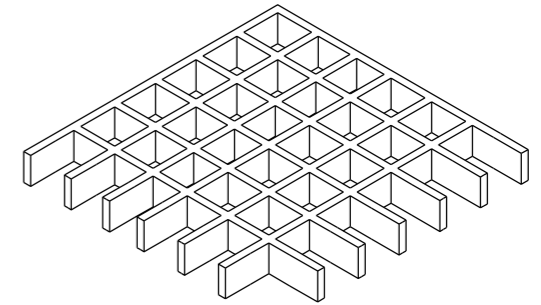

ISOMETRIC VIEW  
N.T.S.

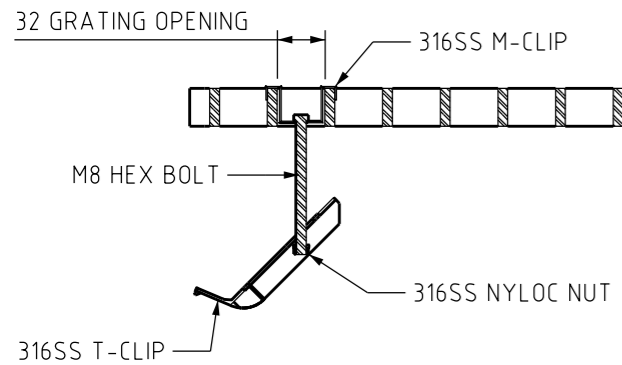

UNLOCK POSITION SECTION A  
N.T.S.

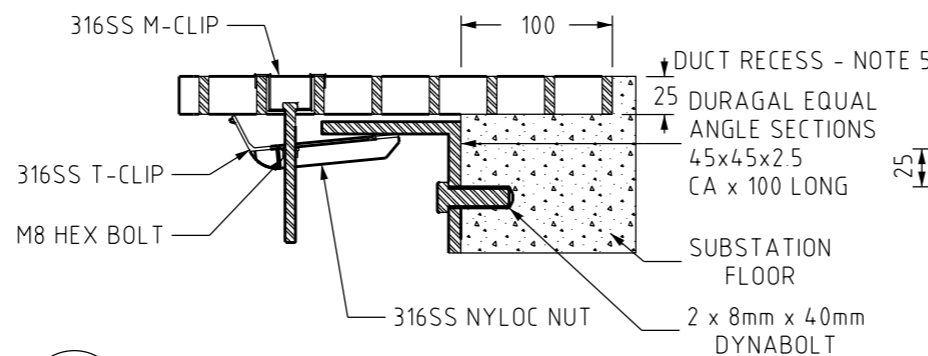

LOCKED POSITION SECTION B  
N.T.S.

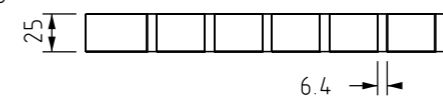

FRONT ELEVATION  
N.T.S.

**PRODUCT DETAILS**

TREADWELL GrafEX SQUARE MESH MODEL: GTX-253838SS-ITGG3.

WEIGHT: 12.3kg/m<sup>2</sup>

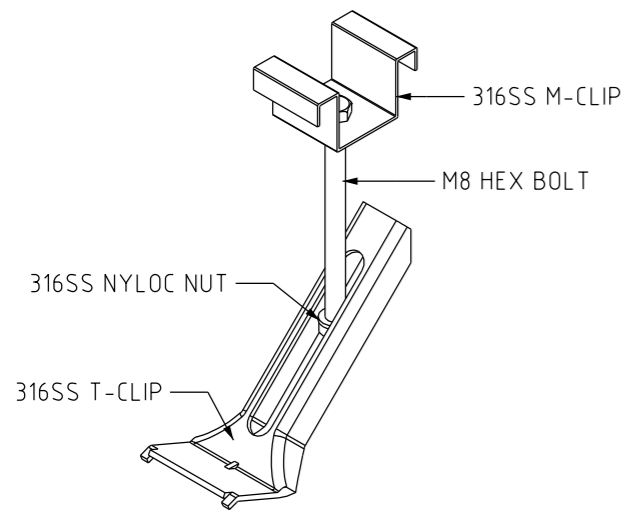

M-T CLIP ASSEMBLY ISOMETRIC VIEW  
N.T.S.

**NOTES**

1. MAXIMUM SPAN OF EACH PANEL IS 15m. MAXIMUM PERMITTED SPAN OF EACH PANEL IS TO ENSURE ACCEPTABLE MASS LIMITS FOR PANEL REMOVAL WHEN CABLE ACCESS IS REQUIRED.
2. ALL PANELS SHOULD BE MEASURED AND CUT TO SIZE WITH NO JAGGED EDGES. WATER JET CUTTING IS RECOMMENDED.
3. TREADWELL PANEL CLIPS ARE TO BE USED AS REQUIRED TO ELIMINATE EXCESS PANEL MOVEMENT INCLUDING BOWING AND LIFTING. REQUIREMENT FOR PANEL CLIPS AND FASTENINGS MAY NOT BE APPARENT UNTIL PANELS ARE INSTALLED.
4. THIS STANDARD APPLIES TO GREENFIELD INSTALLATIONS.
5. THIS STANDARD IS ALSO SUITABLE FOR BROWNFIELD INSTALLATIONS ONLY FOR DUCT RECESS DEPTH 15mm TO 35mm. FOR DUCT RECESS OUTSIDE OF THIS RANGE, REFER TO THE STANDARDS DEPARTMENT FOR ALTERNATIVE SOLUTION.
6. ALL SHARP CORNERS, EDGES AND BURRS ON DURAGAL ANGLE SHALL BE REMOVED.
7. FOR INSTALLATIONS WITH WIDER NON STANDARD TRENCHES, A THICKER VERSION OF DUCT COVER IS PERMITTED FOR USE. ENSURE THAT THE DUCT RECESS DIMENSIONS MATCH THE HEIGHT OF THE DUCT COVER AS TO ACHIEVE A FLOOR WITHOUT TRIP HAZARDS. CONSULT THE VENDOR TO DETERMINE THE CORRECT PRODUCTS FOR THE APPLICATION.

NO	DESCRIPTION	DRN	DATE	CKD	APPD
8	ADDED NOTE 7	P.BH.	DEC'22	B.V.	B.C.
7	INCLUDE DUCT RECESS DIMENSIONS	C.C.	NOV'21	B.V.	A.N.
6	UPDATED MODEL NUMBER AND NOTE 1.	A.N.	SEP'21	A.N.	B.V.
5	NEW MESH PANEL & CLIP ASSEMBLY - CABLE LAYOUT REMOVED - NEW TITLE	C.C.	OCT '20	B.V.	B.C.
4	TITLEBLOCK & DRAWING NUMBER FORMATTED	K.T.	APR '19	C.C.C.	C.C.C.
3	TRENCH LAYOUT AMENDED	-	MAR '90	-	-
2	GENERAL REVISION TITLE AND DRAWING NUMBER AND ITEM A NOTES CHANGED	-	JUN '88	-	-



DES		POWER STANDARD DRAWING	
DES	G.M.SHANAG		
DRN	R.P.P.		
CKD	-		
APPD	-		
SCALE	AS SHOWN		
ISSUED	05/02/1986	A3	DRAWING NUMBER S02-02-07-01
ALL DIM. IN mm			
DRAFTING STANDARD TO A.S.1100			CAD PRODUCT - DO NOT AMEND MANUALLY

