

HV STRAIN PLATE
(FOR METAL AND 125x125 FIBREGLASS X-ARM)
MATERIAL: 100 x 6 DURAGAL CF
ITEM NUMBER: 406938

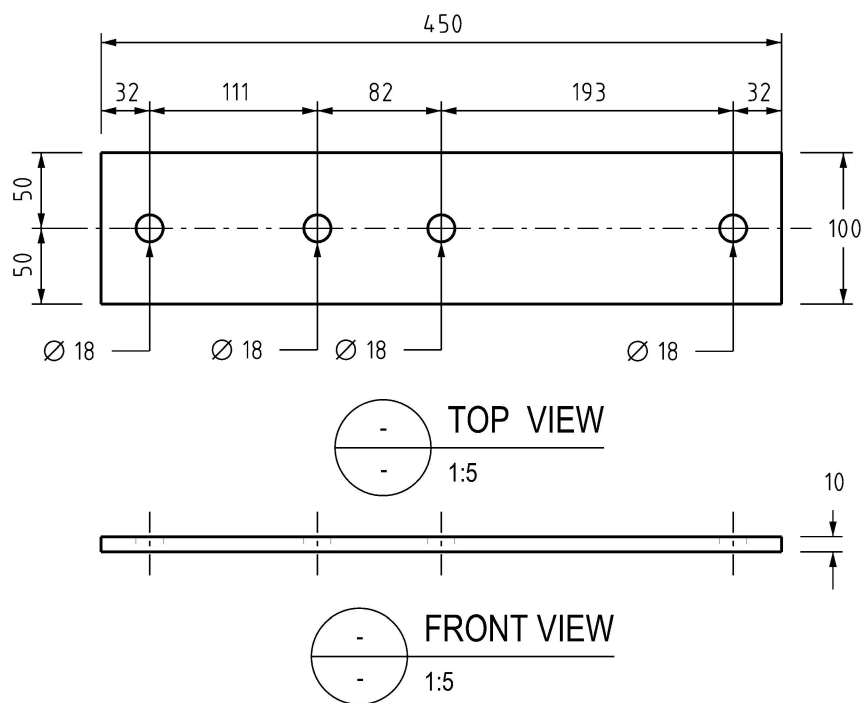

LV 'B' TOP PLATE
MATERIAL: 100 x 10 MILD STEEL CF
ITEM NUMBER : 298661
HOT DIPPED GALVANIZED ITEM NUMBER : 411556

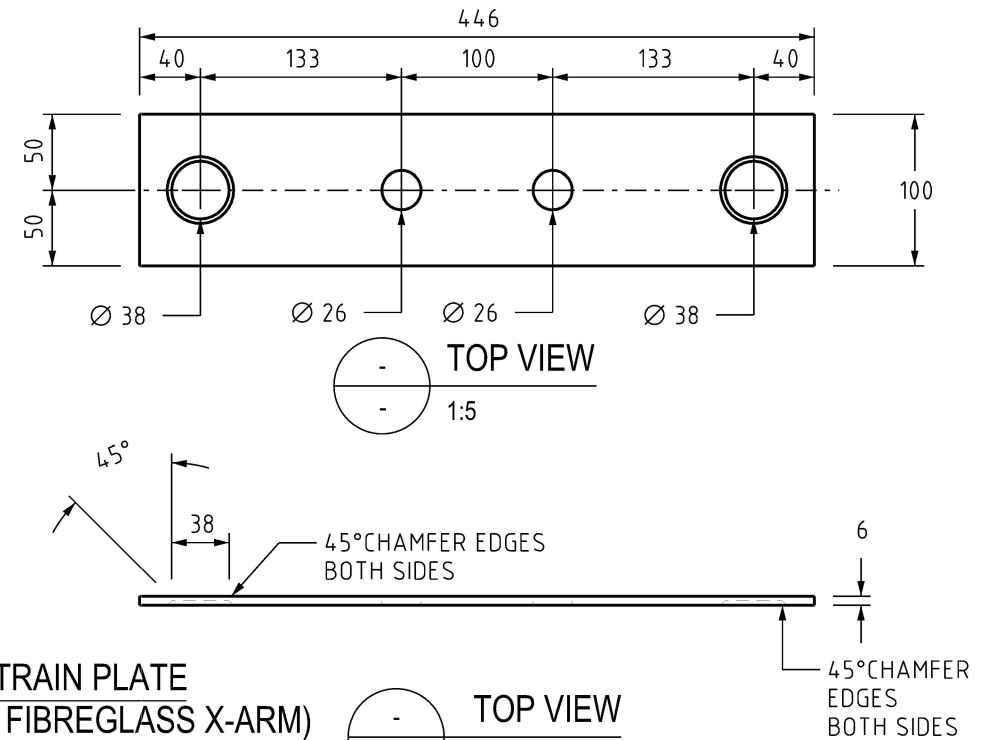

HV STRAIN PLATE
(FOR 200x100 FIBREGLASS X-ARM)
MATERIAL: 100 x 6 CF
DURAGAL ITEM NUMBER : 298653

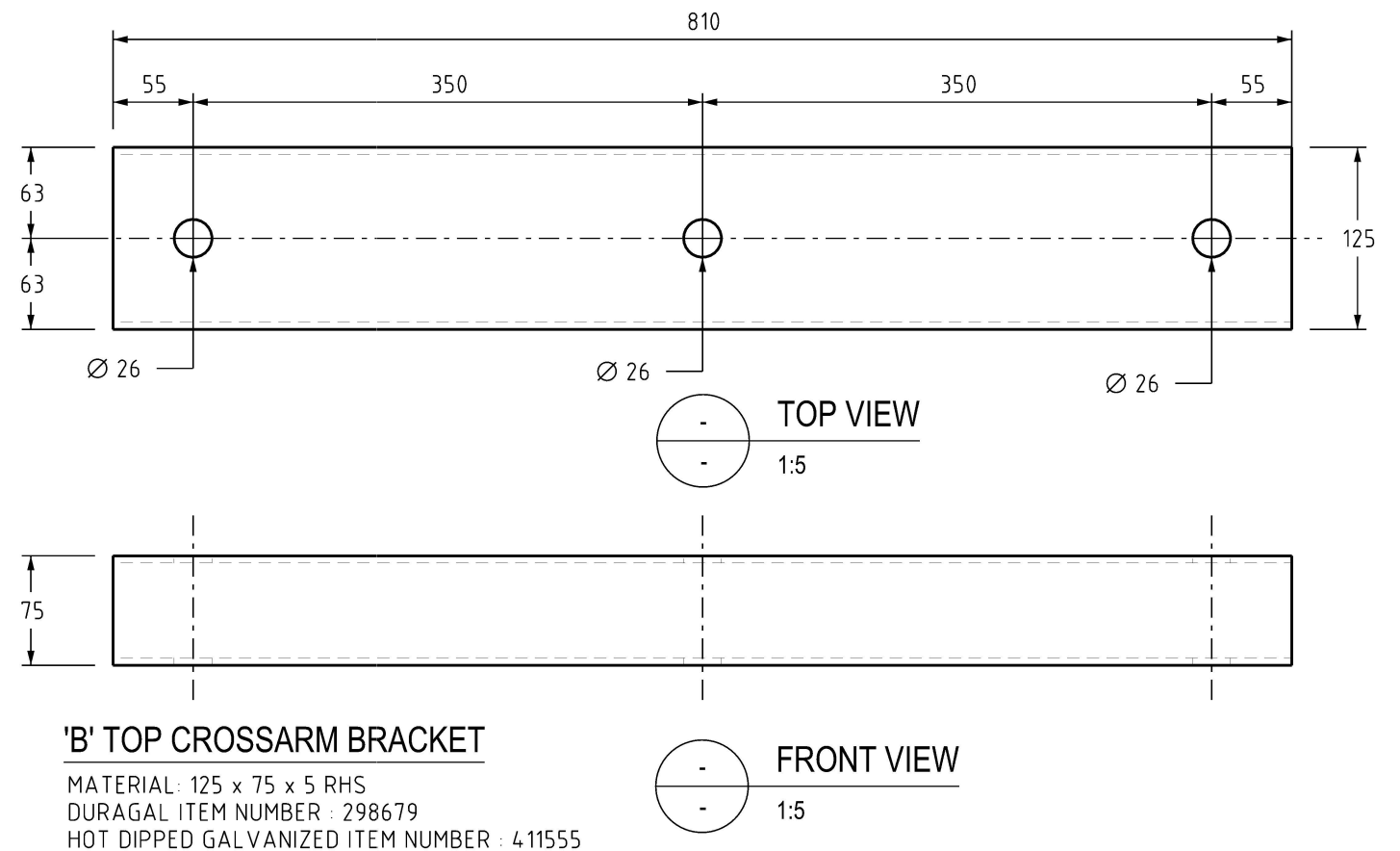

'B' TOP CROSSARM BRACKET
MATERIAL: 125 x 75 x 5 RHS
DURAGAL ITEM NUMBER : 298679
HOT DIPPED GALVANIZED ITEM NUMBER : 411555

NO	DESCRIPTION	DRN	DATE	CKD	APPD
8	HV STRAIN PLATE HOLE DIMENSION AMENDED, TITLE & LABELS UPDATED & SHEET 2 ADDED	C.C.	FEB'21	B.V.	B.C.
7	NAME CHANGE FROM STRAP TO PLATE	C.C.	DEC'20	B.V.	B.C.
6	UPDATED TO 3D MODELS	C.C.	NOV'19	B.V.	B.V.
5	TITLEBLOCK & DRAWING NUMBER FORMATTED	K.T.	DEC'18	C.C.	C.C.
4	HOT DIPPED GALVANIZED ITEMS ADDED	A.T.	NOV'11	B.C.	S.C.
3	STOCK CODE ADDED	R.S.	APR'07	R.S.	B.C.
2	HV SHACKLE STRAP FOR FIBRE GLASS X-ARM ADDED LV SPACER MILD STEEL INST. OFF DURAGAL.	K.I.	JAN'07	PWC	B.C.
1	"B" TOP CROSSARM BRACKET 125x75x5 INST. OFF 125x75x6	A.S.	MAR'02	M.B.	



DES	M. BOCK	POWER STANDARD DRAWING	
DRN	R. INNES	LINE HARDWARE	
CKD	M. BOCK	HV SHACKLE PLATES	
APPD	F. ROBSON	(SHEET 1 OF 2)	
SCALE	AS SHOWN	A3	DRAWING NUMBER S01-01-04-37_1
ISSUED	JULY 2000		
ALL DIM. IN mm			
DRAFTING STANDARD TO A.S.1100		CAD PRODUCT - DO NOT AMEND MANUALLY	



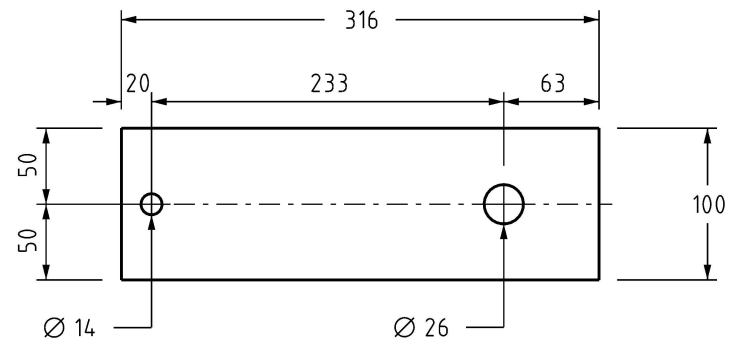

TOP VIEW
1:5

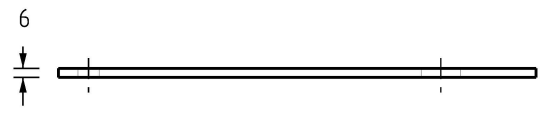

FRONT VIEW
1:5

**FUSESAVER HV STRAIN PLATE
MIDDLE PHASE ONLY
(FOR 125x125 FIBREGLASS X-ARMS)**
MATERIAL: 100 x 6 DURAGAL CF
ITEM NUMBER: 504684

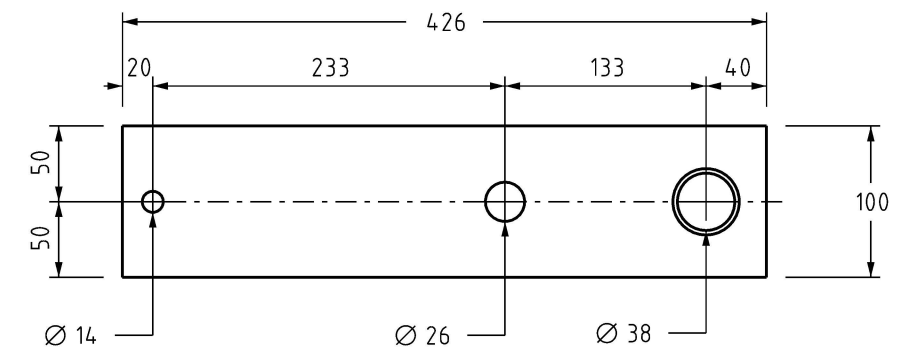

TOP VIEW
1:5

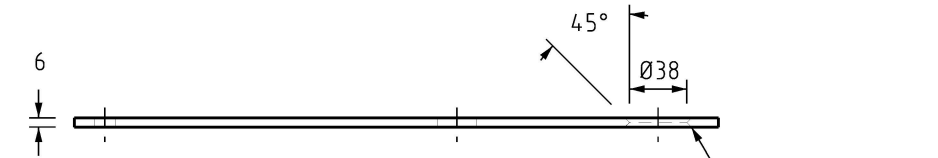

FRONT VIEW
1:5

**FUSESAVER HV STRAIN PLATE
OUTER PHASES ONLY
(FOR 125x125 FIBREGLASS X-ARMS)**
MATERIAL: 100 x 6 DURAGAL CF
ITEM NUMBER: 504683

NOTES:

SHEET 2 CAN BE USED TOGETHER WITH 125x75 HV TERMINATION X-ARM 406841 FOR FUSESAVER T-OFF INSTALLATION IN WELDED CONSTRUCTION.

NO	DESCRIPTION	DRN	DATE	CKD	APPD
0	ISSUED FOR CONSTRUCTION	C.C.	FEB'21	B.V.	B.C.
AMENDMENTS					



DES		POWER STANDARD DRAWING	
DES	H.ETESAMI	LINE HARDWARE HV SHACKLE PLATES (SHEET 2 OF 2)	
DRN	C.COPPINS	A3	DRAWING NUMBER S01-01-04-37_2
CKD	H.ETESAMI		
APPD	B.CHEUNG	DRAFTING STANDARD TO A.S.1100	
SCALE	AS SHOWN	CAD PRODUCT - DO NOT AMEND MANUALLY	
ISSUED	JANUARY 2021	AMDT	
ALL DIM. IN mm			