

- ITEM 1 - 12.0m SINGLE OUTREACH
ITEM NUMBER 112888
- ITEM 2 - 12.0m DOUBLE OUTREACH
ITEM NUMBER 112896
- ITEM 3 - 9.0 m SINGLE OUTREACH
ITEM NUMBER 8953
- ITEM 4 - 9.0 m DOUBLE OUTREACH
ITEM NUMBER 504554

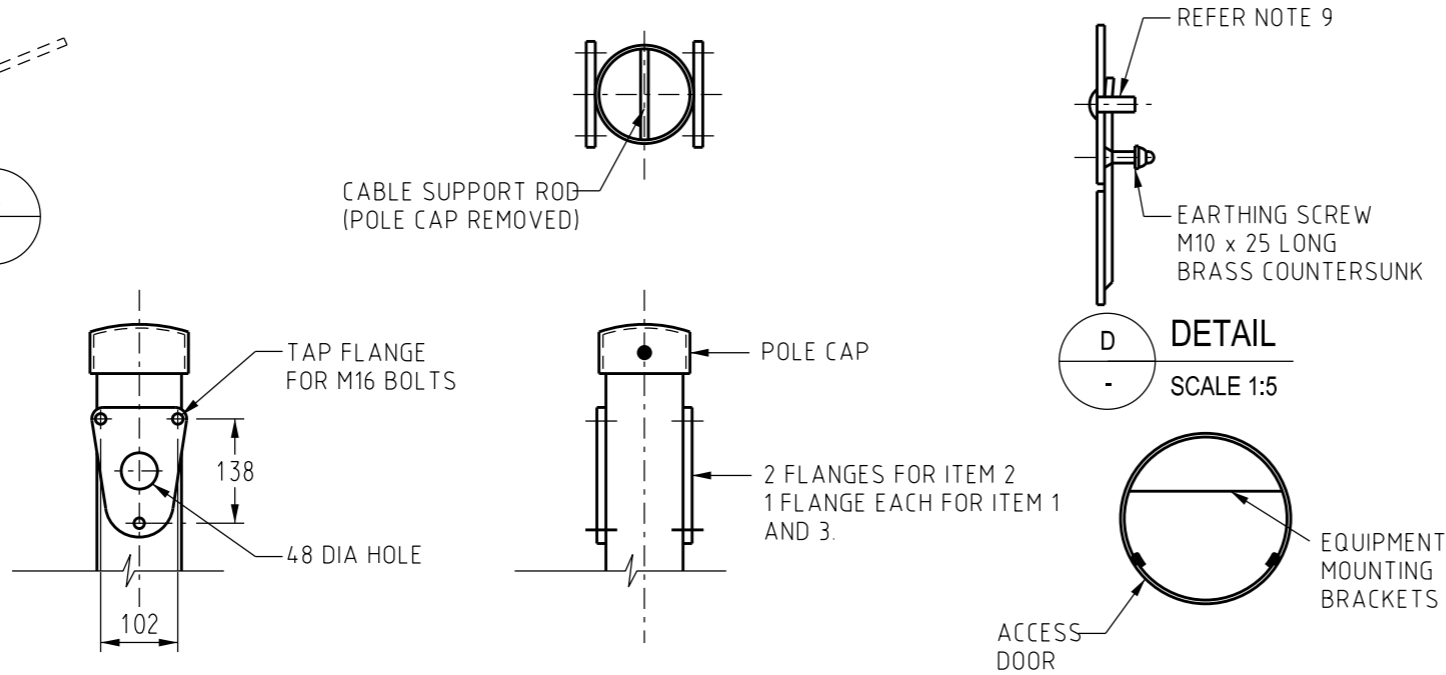

A OUTREACH MOUNTING PLATE - DETAIL
SCALE 1:10

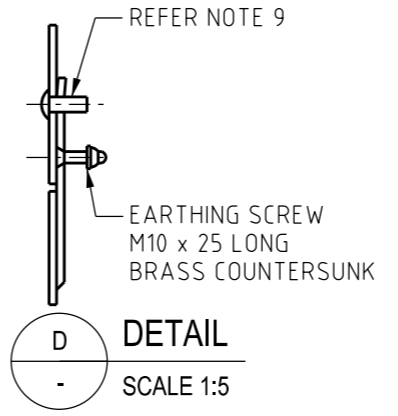

D DETAIL
SCALE 1:5

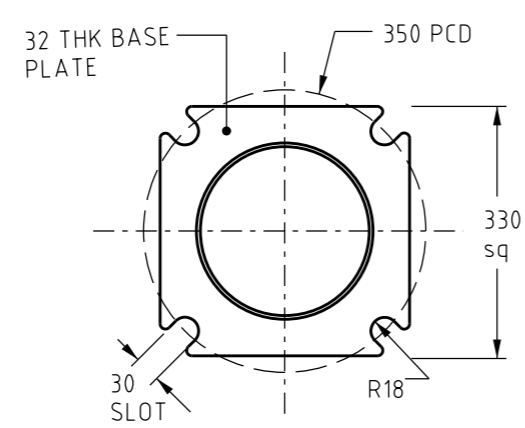

B BASE PLATE - DETAIL
SCALE 1:15

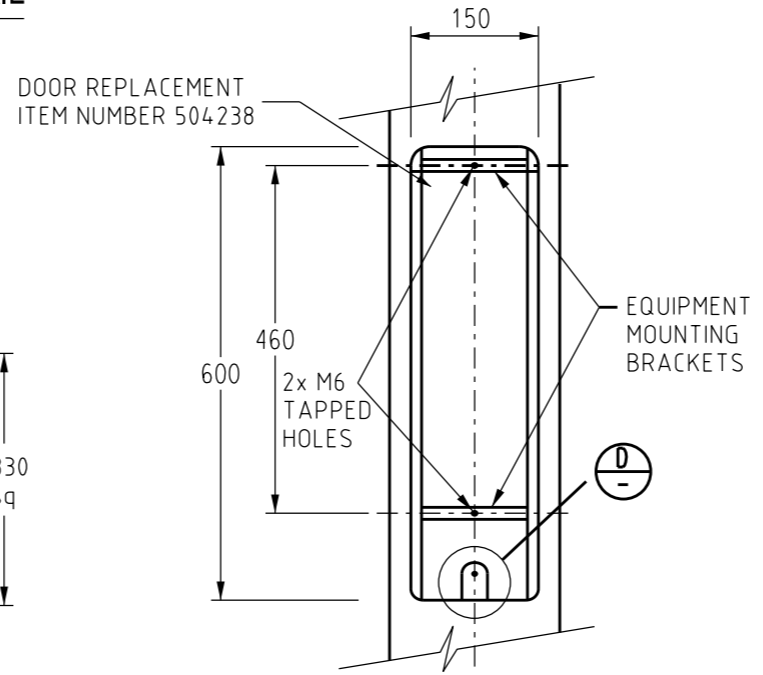

C EQUIPMENT ACCESS - DETAIL
SCALE 1:10 (DOOR REMOVED FOR CLARITY)

NOTES :

1. ALL WELDING AND WELD PREPARATION SHALL BE IN ACCORDANCE WITH AS1554.
2. CIRCUMFERENTIAL WELDS TO BE FILLET. LONGITUDINAL WELDS TO BE SINGLE BUTT TYPE. LONGITUDINAL WELDS TO BE MADE BY CONTINUOUS AUTOMATIC PROCESS AND ARE NOT TO BE DRESSED SMOOTH.
3. AFTER FABRICATION ALL COMPONENTS TO BE ACID DE-SCALED AND HOT DIPPED GALVANIZED TO AS4680.
4. WIND LOADINGS TO COMPLY WITH THE REQUIREMENTS OF AS1170.2 - SECTION 4 DESIGNS ARE TO BE BASED ON -
- MAXIMUM WIND SPEED OF $V_u = 61\text{m/sec}$ DERIVED FROM A DESIGN LIFE OF 25 YEARS.
- MAXIMUM WIND SPEED OF $V_s = 28\text{m/sec}$ DERIVED FROM A DESIGN LIFE OF 25 YEARS WITH A MAXIMUM DEFLECTION LIMIT OF 5% OF NOMINAL LENGTH.
- REGION 'C' AND TERRAIN CATEGORY '2'
5. COLUMNS ARE TO CONFORM TO THE REQUIREMENTS OF AS4100 AND AS1798.
6. COLUMNS ARE TO HAVE CONTINUOUS TAPER OVER THEIR ENTIRE LENGTH AND A STEEL THICKNESS OF NOT LESS THAN 3mm.
7. TWO PIECE COLUMNS MUST BE ASSEMBLED PRIOR TO DELIVERY.
8. ACCESS DOORS ARE NOT INTERCHANGEABLE. ENSURE THAT INDIVIDUAL COLUMNS AND DOORS ARE SUITABLY MATCHED AND MARKED.
9. EQUIPMENT ACCESS DOOR TO BE PROVIDED (DETAIL C) HAVING 'TAMPER PROOF' LOCKING DEVICE. DOOR ACCESS SCREW TO BE M10 STAINLESS STEEL I.S.O. METRIC BUTTON HEAD SOCKET TYPE.
10. ALL COLUMNS ARE TO BE MANUFACTURED TO ACCEPT THE MOUNTING OF OUTREACHES AS SHOWN ON DRAWING S03-01-01-10.
11. ALL POLE MANUFACTURERS SHALL COMPLY WITH ISO 3834.
12. ROUND OR OCTAGONAL POLE SHAPES ACCEPTABLE.

NO	DESCRIPTION	DRN	DATE	CKD	APPD
26	BASE PLATE SLOT SIZE ROLLED BACK	J.R.	DEC'23	B.C.	B.V.
25	NOTES 2 & 4 AMENDED. NOTE 12 ADDED. BASE PLATE SLOT AND THICKNESS SIZE AMENDED.	P.B.H.	MAR'23	B.C.	B.V.
24	NOTES 3 & 4 AMENDED.	P.B.H.	JAN'23	B.C.	B.V.
23	ITEM 4 ADDED	C.W.M.	MAR'20	B.C.	B.C.
22	ADDED DOOR ITEM NUMBER & STOCK CODE REPLACED WITH ITEM NUMBER	C.C.	JUL'19	B.V.	B.C.
21	GALVANIZING STANDARD UPDATED TO AS4680 NOTE 11 ADDED	A.T.	JAN'13	B.C.	B.C.
20	BASE PLATE - DETAIL B AMENDED	J.C.	NOV'08	B.C.	S.C.

PowerWater
 NORTHERN TERRITORY

DES		POWER STANDARD DRAWING	
DRN	A.DAVIS	COLUMN TAPERED STEEL	
CKD	R.INNES	9.0 METRE AND 12.0 METRE	
APPD	F.ROBSON	OUTREACH TYPE	
SCALE	AS SHOWN		
ISSUED	APRIL'98	A3	DRAWING NUMBER S03-01-01-01
ALL DIM. IN mm			
DRAFTING STANDARD TO A.S.1100		CAD PRODUCT - DO NOT AMEND MANUALLY	