

PHYSICAL SPECIFICATION

	DESCRIPTION
SIZE	4" OR 101.6 Diameter Sphere
WEIGHT	NET 0.7587 lb (0.35kg) each. Shipping 24lbs (10.5kg/carton)
PACKAGING	30 Markers/Carton
RANGE	5ft (1.5m) from locator probe
SHELL	High-density polyethylene
COLOUR	RED

ENVIRONMENTAL SPECIFICATIONS

OPERATING TEMP	-22° TO 150°F (-30° TO 66°C)
STORAGE TEMP	-40° to 167°F (-40° to 75°C)

NOTES:

TO BE BURIED AT ALL CABLE JOINT LOCATIONS, CABLE TURNING PITS, OR OTHER UNDERGROUND LOCATION REQUIREMENTS.

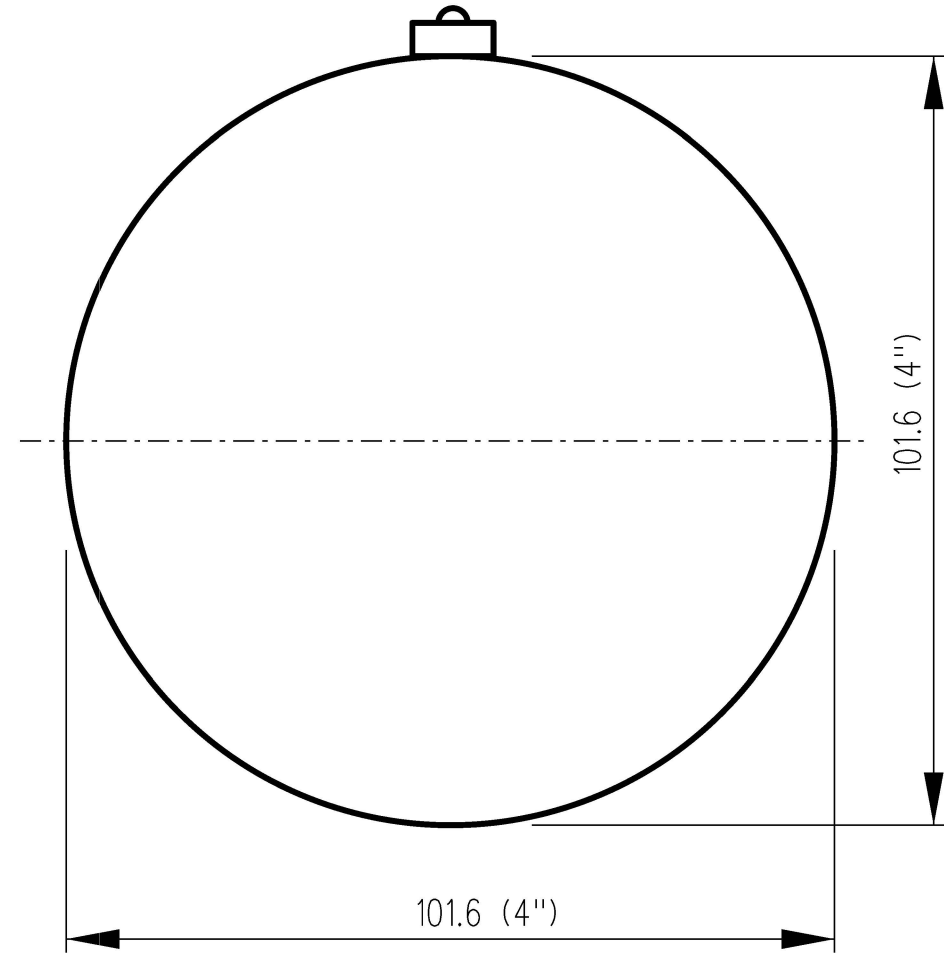

ITEM NUMBER: 402365

						DES	J.D.	POWER STANDARD DRAWING			
						DRN	K.I.	SIGNS ELECTRONIC MARKER UNDERGROUND			
						CKD	C.C.				
						APPD	...				
						SCALE	1:1	A3	DRAWING NUMBER	S02-01-08-23	AMD T
						ISSUED	FEB '05				
						ALL DIM. IN	mm	CAD PRODUCT - DO NOT AMEND MANUALLY			
						DRAFTING STANDARD TO A.S.1100					
						J.R.	DEC'24	B.B.	B.V.		
						C.C.C.	OCT '19	M.Sc.	C.C.C.		
						K.I.	FEB '05	C.C.			
2	AMENDED NOTES.										
1	UPDATE TITLEBLOCK & PAD DRAWING NOs										
0	ISSUED FOR APPROVAL										
NO	DESCRIPTION	DRN	DATE	CKD	APPD						
AMENDMENTS											