

TYPE 'A' LOWERING

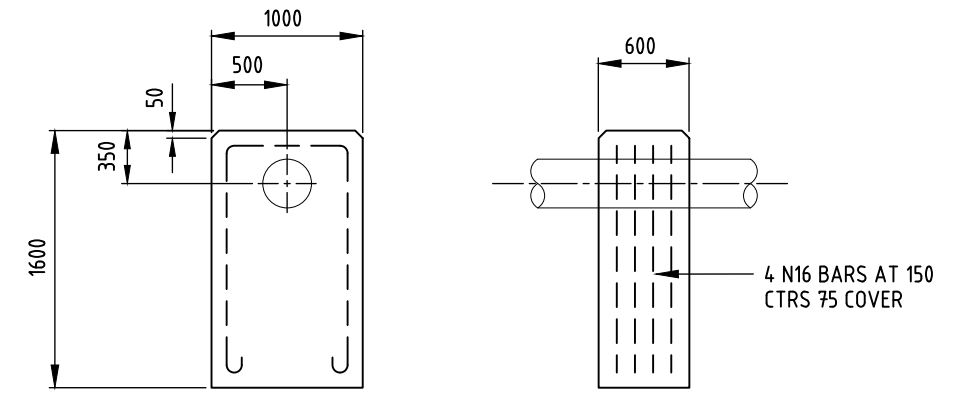

DETAILS OF ANCHOR BLOCK
REFER W1-2-05B

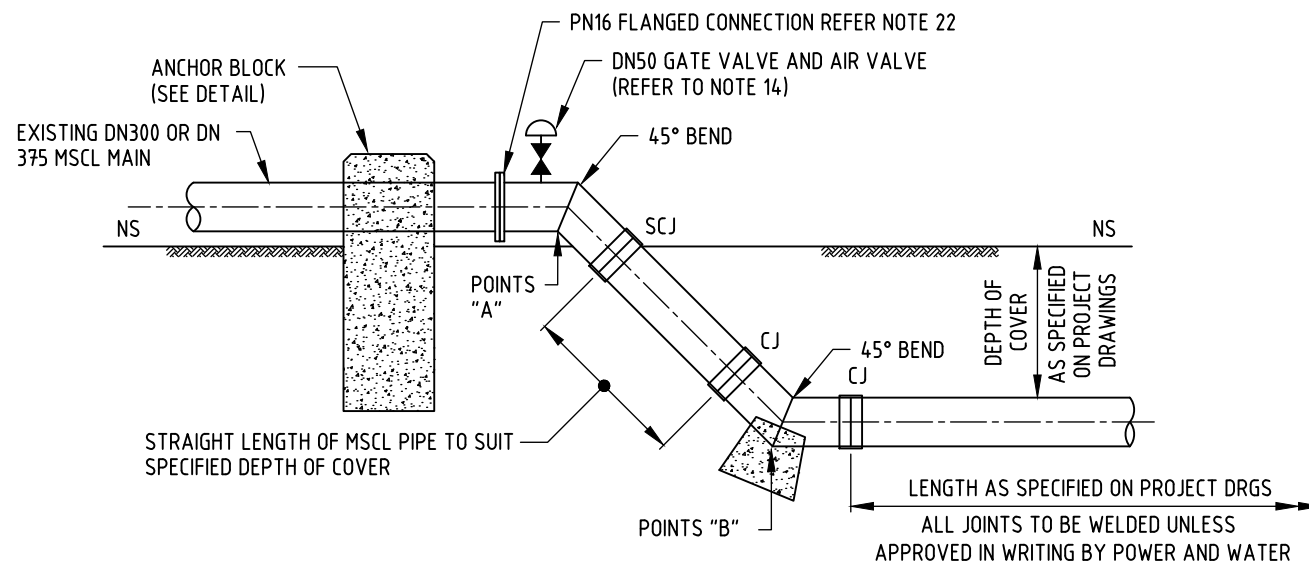

TYPE 'B' LOWERING

STANDARD PROCEDURE FOR LOWERING OF MAINS

1. THE CONTRACTOR SHALL SUPPLY ALL MATERIAL REQUIRED FOR THE CONNECTION.
2. UNPAINTED PARTS SHALL BE SAND BLASTED AND PAINTED AFTER RECONNECTION.
3. CONCRETE FOR THRUST AND ANCHOR BLOCKS SHALL BE CLASS N25 IN ACCORDANCE WITH AS.1379 AND AS.3600.
4. THIS DRAWING IS TO BE READ IN CONJUNCTION WITH LOCALITY PLAN AND SPECIFIED JOB DETAILS.
5. THE PIPE LINE SHALL BE EVENLY GRADED BETWEEN POINT A AND B.
6. THE MAXIMUM LENGTH OF PIPE TO BE LIFTED BY ONE CRANE IS 30m. SIMILAR CRANES MUST BE USED IF POSSIBLE. IF NOT, THE CRANES MUST BE CAREFULLY COORDINATED AND SHORTER LENGTHS LIFTED, AS APPROVED.
7. WELDING SHALL BE IN ACCORDANCE WITH AS 1554 PART 1. WELDING OPERATORS SHALL BE SUITABLY QUALIFIED TO A STANDARD ACCEPTABLE TO POWER AND WATER.
8. MINIMUM COVER, WHERE THE PIPE IS BURIED TO BE:
(A) 750mm BELOW FINISHED SURFACE LEVEL OF THE CARRIAGEWAY
(B) 750mm BELOW NATURAL SURFACE LEVEL ELSEWHERE
(C) 1500mm TO TOP OF SLEEVE IF INSTALLED BY TRENCHLESS TECHNIQUES
9. OLD BITUMEN AND PAINT SHALL BE REMOVED FROM THE PIPE WITHOUT DAMAGING THE SURFACE OR CEMENT LINING. THE PIPE SHALL BE BLASTED TO CLASS 3 FINISH AND TO AS 1627 PART 4 (ALSO SEE NOTE 15 BELOW).
10. AFTER SANDBLASTING, A CHECK SHALL BE MADE FOR DEFECTS IN PIPE AND ON OLD WELDS. IF THERE ARE ANY VISIBLE DEFECTS, THESE SHALL BE REPAIRED.
11. HANDLING COATED PIPES - CARE MUST BE TAKEN NOT TO DAMAGE THE COATED SURFACE, WEBBED BANDS (NOT WIRE SLINGS) SHALL BE USED FOR LOWERING THE PIPE AFTER SAND BLASTING. IF THE PIPE IS TO BE ROLLED OVER OR MOVED AFTER LOWERING, SOFT MATERIAL OR/AND BAGS SHALL BE PLACED UNDER IT. NO STONES OR HARD MATERIAL SHALL BE PRESENT IN THE SAND BEDDING UNDER THE PIPE.
12. POWER AND WATER ONLY SHALL BE RESPONSIBLE FOR TURNING THE WATER OFF AND ON FOR ISOLATION.
13. POWER AND WATER DOES NOT GUARANTEE THE WATER MAIN TO BE FREE OF WATER AT THE TIME OF CUTTING OR RECONNECTION.
14. DN50 RESILIENT SEATED GATE VALVE AND DN50 STAINLESS STEEL FLANGED AIR VALVE TO BE INSTALLED ON BOTH SIDES WHERE CHANGE OF GRADE OCCUR. REINFORCEMENT PLACE (REFER DETAIL ON TYPE 'A' AND TYPE 'B' LOWERING) REQUIRED FOR DN375 MAIN.
15. A PROTECTIVE PETROLATUM MASTIC TAPING SYSTEM SIMILAR OR EQUAL TO 'DENSO' MAY BE USED, AND APPLIED IN ACCORDANCE WITH THE MANUFACTURER'S RECOMMENDATIONS ON BELOW GROUND PIPEWORK.
16. PROVIDE DN100 SCOUR VALVE AT LOWEST POINT IF LENGTH A TO B EXCEEDS 200m, REFER W1-2-14.
17. PROVIDE PN16 RESILIENT SEATED SLUICE VALVE ON UPSTREAM SIDE IF NEAREST UPSTREAM ISOLATION VALVE IS MORE THAN 1000m AWAY SIMILAR CRITERIA FOR DOWNSTREAM SIDE.
18. THRUST BLOCKS TO BE PROVIDED WHERE LENGTH A TO B IS NOT FULLY WELDED.
19. REFER W1-2-06A FOR BENDS AND FITTING DETAILS.
20. FOR DN300 MAIN, USE DN500 API 52 MILD STEEL SLEEVE WITH 9.53mm WALL FOR DN300 MAIN, USE DN 600 API 52 MILD STEEL SLEEVE WITH 9.53mm WALL.
21. BENDS AND FITTINGS CAN BE FABRICATED LOCALLY USING EXISTING MSCL WHERE APPROVED IN WRITING BY POWER AND WATER.
22. EXISTING DN300 ABOVE GROUND MAINS, TYPICALLY 337mm OD AND 6m WALL THICKNESS. EXISTING DN375 ABOVE GROUND MAINS TYPICALLY 419mm OD AND 4.5mm WALL THICKNESS.
23. USE 8mm THICK PLATE FOR WELD COLLAR.
24. CJ - COLLAR JOINT, SCJ - SPECIAL COLLAR JOINT

3	NOTES AMENDED.	J.W.	JAN'24	J.C.	D.C.
2	GENERAL AMENDMENTS 2021.	P.W.	JUNE'21	J.R.	D.C.
1	REDRAWN ON AUTOCAD.	A.W.	OCT'18	J.R.	D.C.
NO	DESCRIPTION	DRN	DATE	CKD	APPD
	AMENDMENTS				



DES	J.C.	WATER STANDARD DRAWING		
DRN	L.M.	MAINLAYING		
CHK	V.G.	LOWERING OF DN300 AND DN375		
APPD	D.C.	MSCL MAINS		
SCALE	N.T.S.	A3	DRAWING NUMBER	W1-2-08
ISSUED	OCT'17			
ALL DIM. IN mm		DRAFTING STANDARD TO A.S.1100		CAD PRODUCT - DO NOT AMEND MANUALLY
				3
				AMDT